



Parts Manual

HydroCut Series

Walk-Behind Mower



Models:

5900604

HC32KAV13

HC36KAV13E

Ferris Industries

5375 North Main Street
Munnsville, NY 13409 USA
800-933-6175

5022949
Revision 08
Rev. Date: 4/2005
TP 400-7077-08-HC-F

MODEL COMPONENTS	PAGE
Engine Frame & Handle Bars Group - Electric Start	4
Engine Frame & Handle Bars Group - Manual Start	6
Fuel Supply Hose & Tank Replacement Parts Group - Electric Start	8
Fuel Supply Hose & Tank Replacement Parts Group - Manual Start	10
Fuel Tank & Mount Group	12
Engine, PTO & Deck Drive Idler Group - Manual Start	14
Engine, PTO & Deck Drive Idler Group - Electric Start	16
Motion Control, Parking Brake & Operator Presence Group - Electric Start	18
Motion Control, Parking Brake & Operator Presence Group - Manual Start	20
Transaxle & Mount Group	22
Transaxle - SERVICE PARTS	24
Tire & Wheel Group	26
Decals - Brand & Model	28
Decals - Safety & Instruction	30
32" Mower Deck - Frame, Caster & Shield	32
32" Mower Deck - Height Adjustment	34
32" Mower Deck - Housing, Spindles, Blades & Pulleys	36
36" Mower Deck - Frame, Caster & Shield	38
36" Mower Deck - Height Adjustment	40
36" Mower Deck - Housing, Spindles, Blades & Pulleys	42
Electrical Group - Electric Start	46
Electrical Group - Manual Start	48
Electrical Schematic - Manual Start	50
Torque Specification Chart	Inside Back Cover

Engine Frame & Handle Bars Group - Electric Start

077hbre0

NOTE: Unless noted otherwise,
use the standard hardware torque
specification chart.

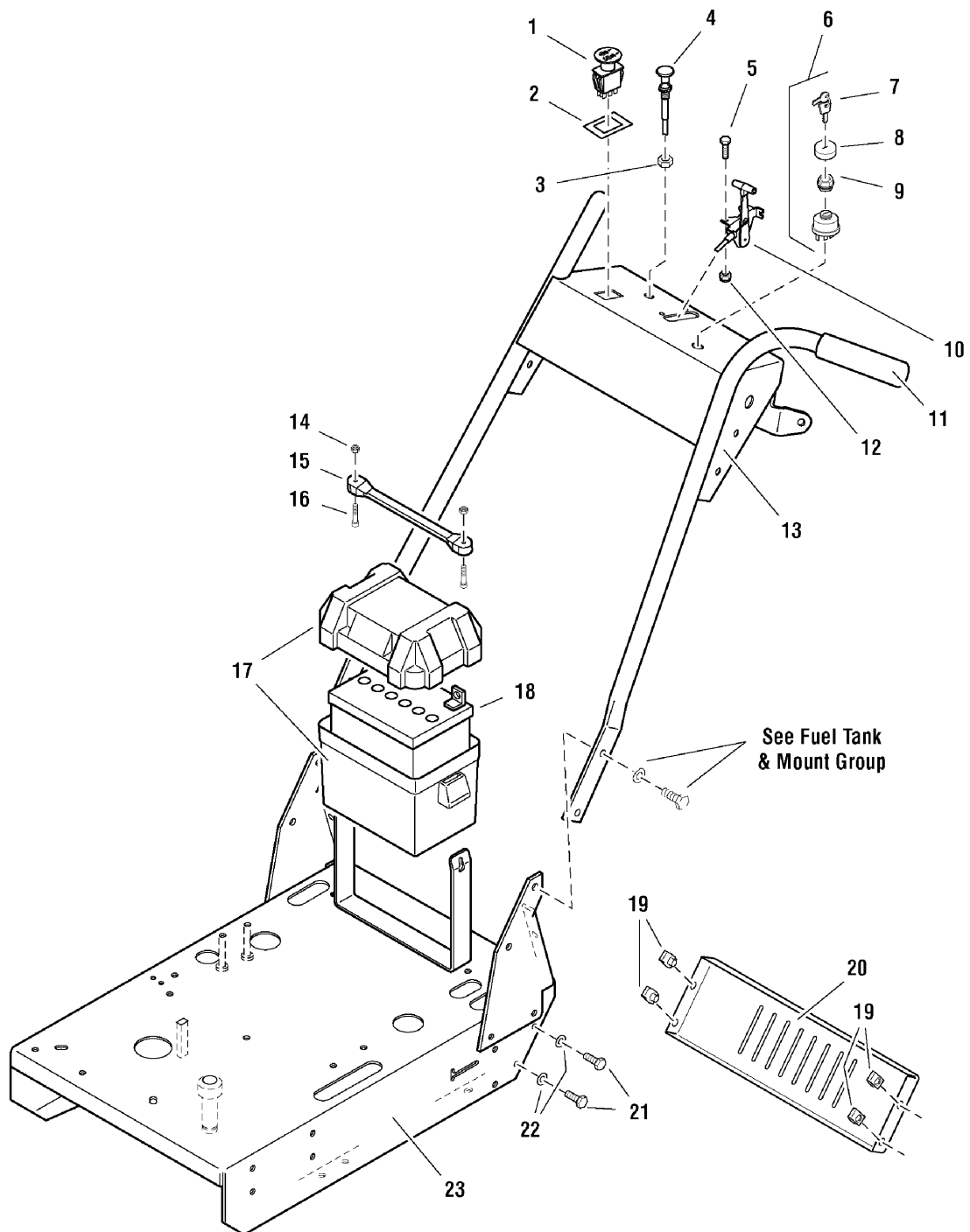

The above parts group applies to the following Mfg. Nos.:

5900604
HC36KAV13E

Engine Frame & Handle Bars Group - Electric Start

REF NO.	PART NO.	QTY.	DESCRIPTION
1	22180	1	SWITCH, PTO
2	22222	1	SWITCH RETAINER RING
3	25035	1	NUT, 3/8-24 Hex
4	46501	1	CABLE, Choke Control, 47"
5	25010-6	2	BOLT, 1/4-20 x 3/4
6	20927	1	SWITCH, Ignition, Complete (Includes Ref No. 7 - 9)
7	22789	1	KEY, Ignition, Molded Set
8	22790	1	COVER
9	22791	1	PLASTIC NUT
10	47629	1	CABLE, Throttle Control, 46"
11	21841	2	GRIP, Foam
12	25095	2	NUT, 1/4-20 Hex Nylon Lock
13	61279	1	HANDLE BAR ASSEMBLY
14	25271	2	NUT, #10-24 Hex Nylon Lock
15	21670	1	RUBBER STRAP
16	25270	2	SCREW, #10-24 x 1
17	46188	1	BATTERY BOX
18	-	1	BATTERY, Lawn & Garden, 12V (BCIU1, 340 CCA)
19	22308	4	BODY CLIP, 5/16-18
20	47735	1	REAR SHIELD
21	25011-6	4	BOLT, 5/16-18 x 3/4
22	25155	4	WASHER, 5/16" SAE
23	49229	1	ENGINE DECK ASSEMBLY

Footnotes

The above parts group applies to the following Mfg. Nos.:

5900604

HC36KAV13E

Engine Frame & Handle Bars Group - Manual Start

077HBRM0

NOTE: Unless noted otherwise,
use the standard hardware torque
specification chart.

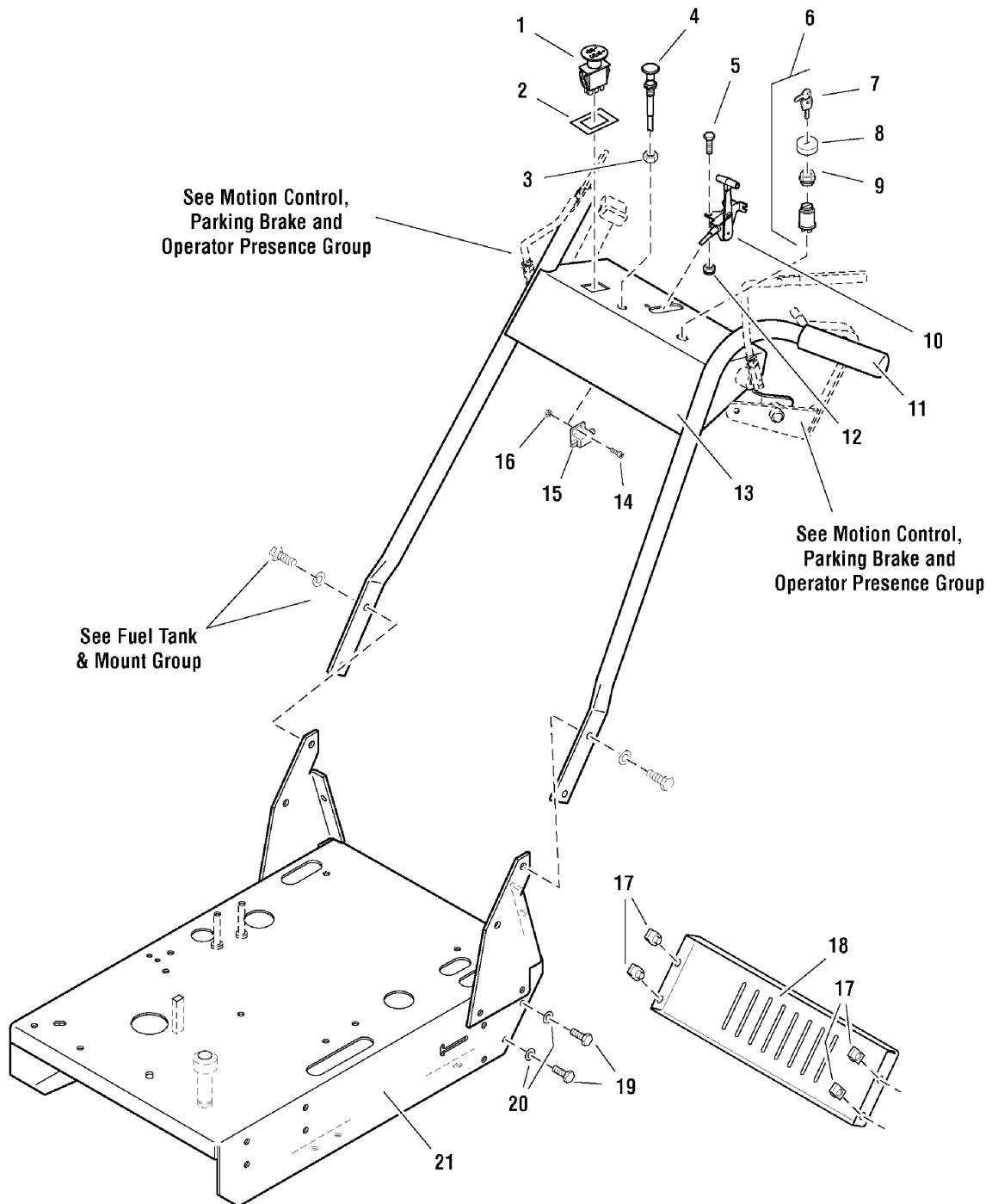

The above parts group applies to the following Mfg. Nos.:
HC32KAV13

Engine Frame & Handle Bars Group - Manual Start

REF NO.	PART NO.	QTY.	DESCRIPTION
1	22180	1	SWITCH, PTO
2	22222	1	SWITCH RETAINER RING
3	25035	1	NUT, 3/8-24 Hex
4	46501	1	CABLE, Choke Control, 47"
5	25010-6	2	BOLT, 1/4-20 x 3/4
6	21842	1	SWITCH, Ignition, Complete (Includes Ref No. 7 - 9)
7	22789	1	KEY, Ignition, Molded Set
8	22790	1	COVER
9	22791	1	PLASTIC NUT
10	47629	1	CABLE, Throttle Control, 46"
11	21841	2	GRIP, Foam
12	25095	2	NUT, 1/4-20 Hex Nylon Lock
13	47905	1	HANDLE BAR ASSEMBLY
14	25179-4	2	SCREW, #10-24 x 1/2
15	21769	1	SWITCH, Plunger, NC
16	25029	2	NUT, #10-24 Hex
17	22308	4	BODY CLIP, 5/16-18
18	47735	1	REAR SHIELD
19	25011-6	4	BOLT, 5/16-18 x 3/4
20	25155	4	WASHER, 5/16" SAE
21	48230	1	ENGINE DECK ASSEMBLY

Footnotes

The above parts group applies to the following Mfg. Nos.:

HC32KAV13

Fuel Supply Hose & Tank Replacement Parts Group - Electric Start

077fshe0

NOTE: Unless noted otherwise,
use the standard hardware torque
specification chart.

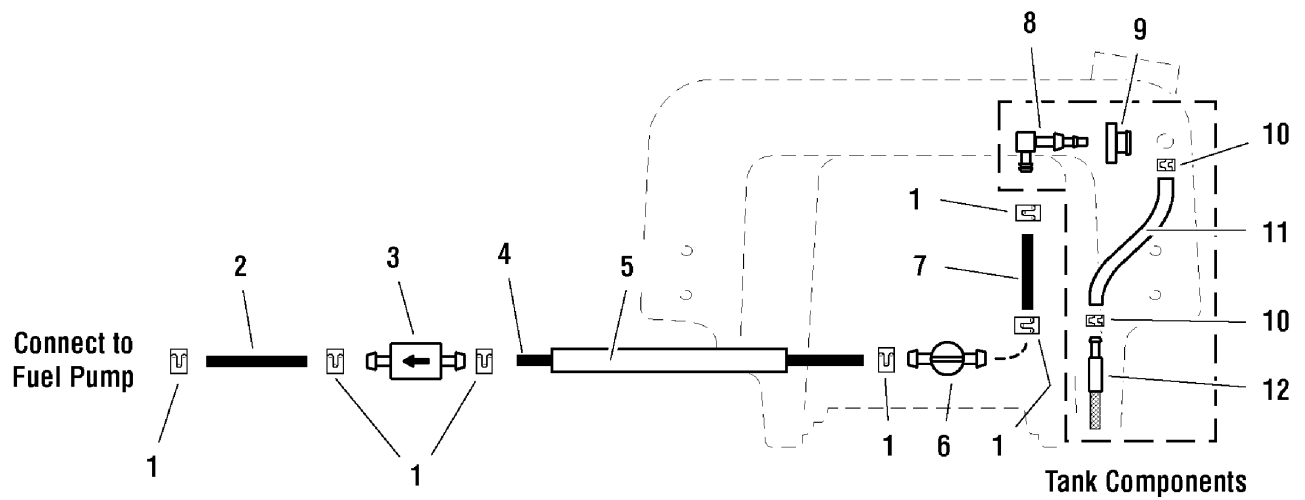

The above parts group applies to the following Mfg. Nos.:

5900604
HC36KAV13E

Fuel Supply Hose & Tank Replacement Parts Group - Electric Start

REF NO.	PART NO.	QTY.	DESCRIPTION
1	20835	6	CLAMP, Hose
2	50831-7	1	1/4" Fuel Line, 7" Long (supplied with engine)
3	21178-3	1	FUEL FILTER
4	50831-35	1	1/4" Fuel Line, 35" Long
5	50833-22	1	WIRE LOOM, 22"
6	21235	1	VALVE, Fuel Shut-Off
7	50831-4	1	1/4" Fuel Line, 4" Long
8	23061	1	ELBOW FITTING
9	1726400	1	GROMMET
10	23069	2	HOSE CLAMP
11	50925-20	1	HOSE, 20"
12	23067	1	SCREEN FITTING

Footnotes

The above parts group applies to the following Mfg. Nos.:

5900604
HC36KAV13E

Fuel Supply Hose & Tank Replacement Parts Group - Manual Start

077FSHM0

NOTE: Unless noted otherwise,
use the standard hardware torque
specification chart.

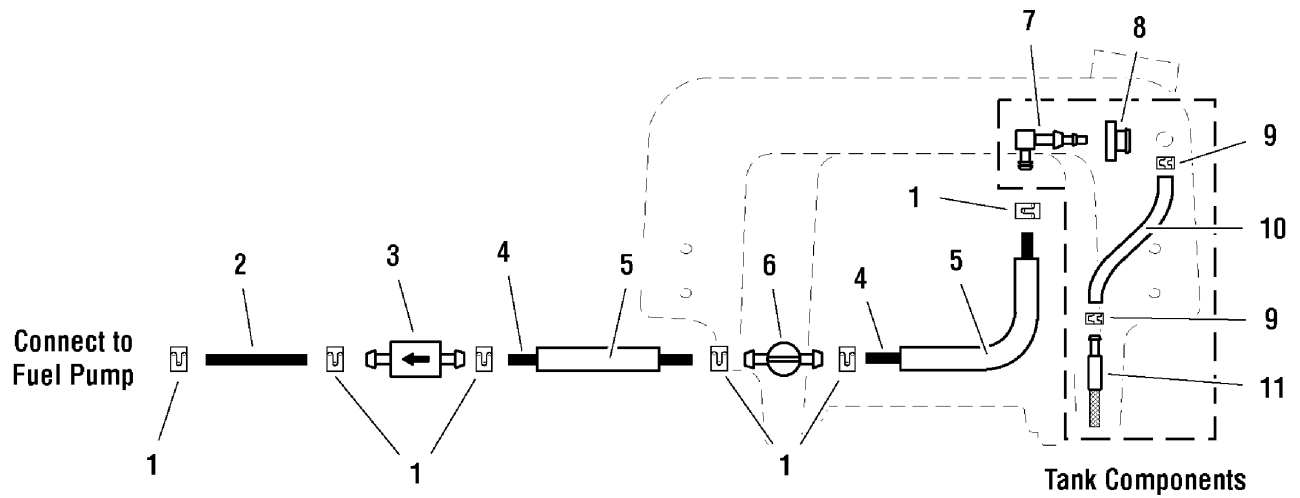

The above parts group applies to the following Mfg. Nos.:
HC32KAV13

Fuel Supply Hose & Tank Replacement Parts Group - Manual Start

REF NO.	PART NO.	QTY.	DESCRIPTION
1	20835	6	CLAMP, Hose
2	50831-7	1	1/4" Fuel Line, 7" Long (supplied with engine)
3	21178-3	1	FUEL FILTER
4	50831-19.5	2	1/4" Fuel Line, 19-1/2" Long
5	50833-18	2	WIRE LOOM, 18"
6	21235	1	VALVE, Fuel Shut-Off
7	23061	1	ELBOW FITTING
8	1726400	1	GROMMET
9	23069	2	HOSE CLAMP
10	50925-20	1	HOSE, 20"
11	23067	1	SCREEN FITTING

Footnotes

The above parts group applies to the following Mfg. Nos.:

HC32KAV13

Fuel Tank & Mount Group

077TNK0

NOTE: Unless noted otherwise,
use the standard hardware torque
specification chart.

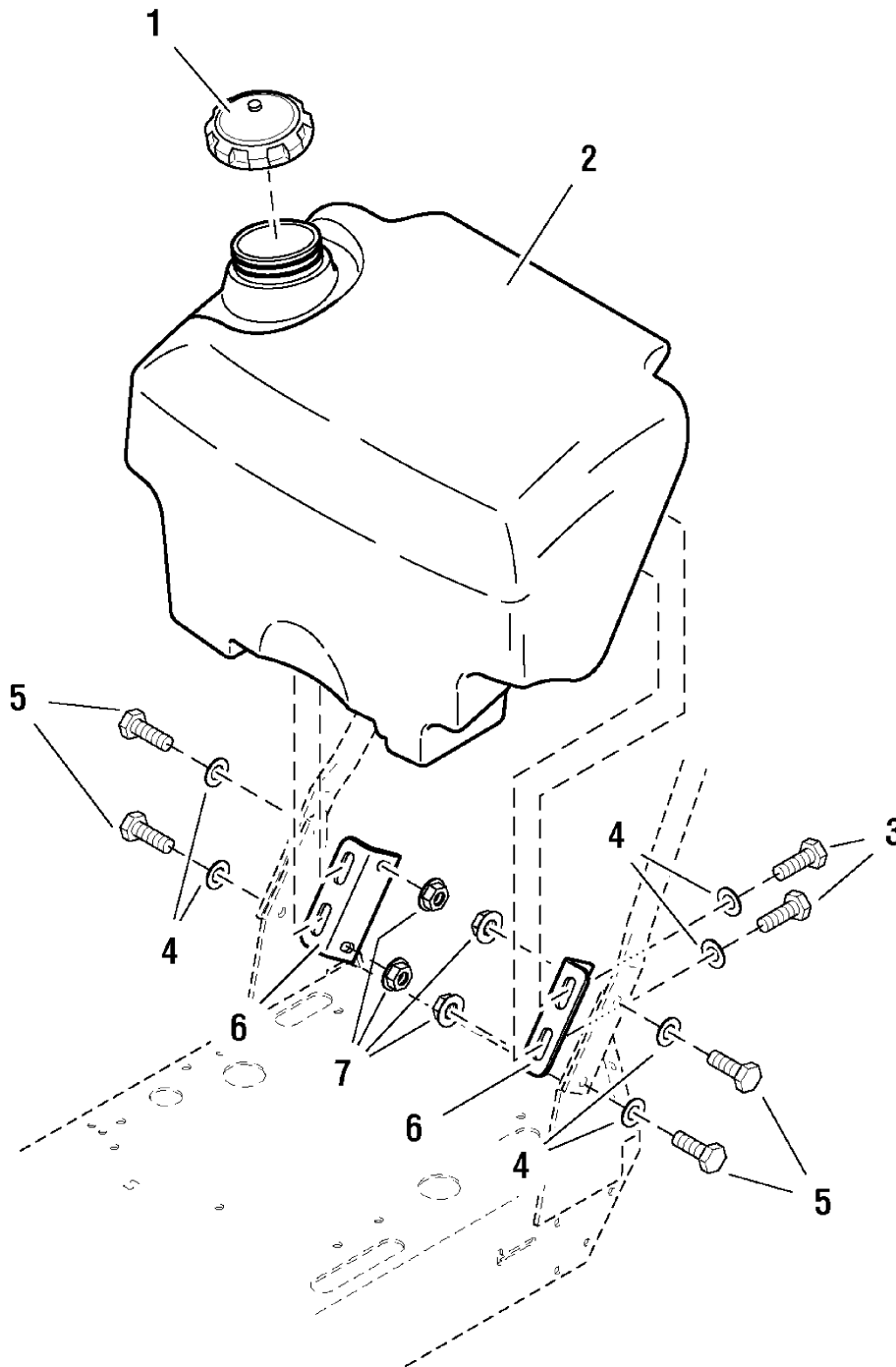

The above parts group applies to the following Mfg. Nos.:

HC36KAV13E

5900604

HC32KAV13

Fuel Tank & Mount Group

REF NO.	PART NO.	QTY.	DESCRIPTION
1	22158	1	FUEL TANK CAP
2	48149	1	FUEL TANK
3	25013-6	4	BOLT, 3/8-16 x 3/4
4	25156	8	WASHER, 3/8" SAE
5	25013-10	4	BOLT, 3/8-16 x 1-1/4
6	49228	2	FUEL TANK MOUNT
7	25128	4	NUT, 3/8-16 Hex Serrated Flange

Footnotes

The above parts group applies to the following Mfg. Nos.:

HC36KAV13E

5900604

HC32KAV13

Engine, PTO & Deck Drive Idler Group - Manual Start

077ENGW0

NOTE: Unless noted otherwise,
use the standard hardware torque
specification chart.

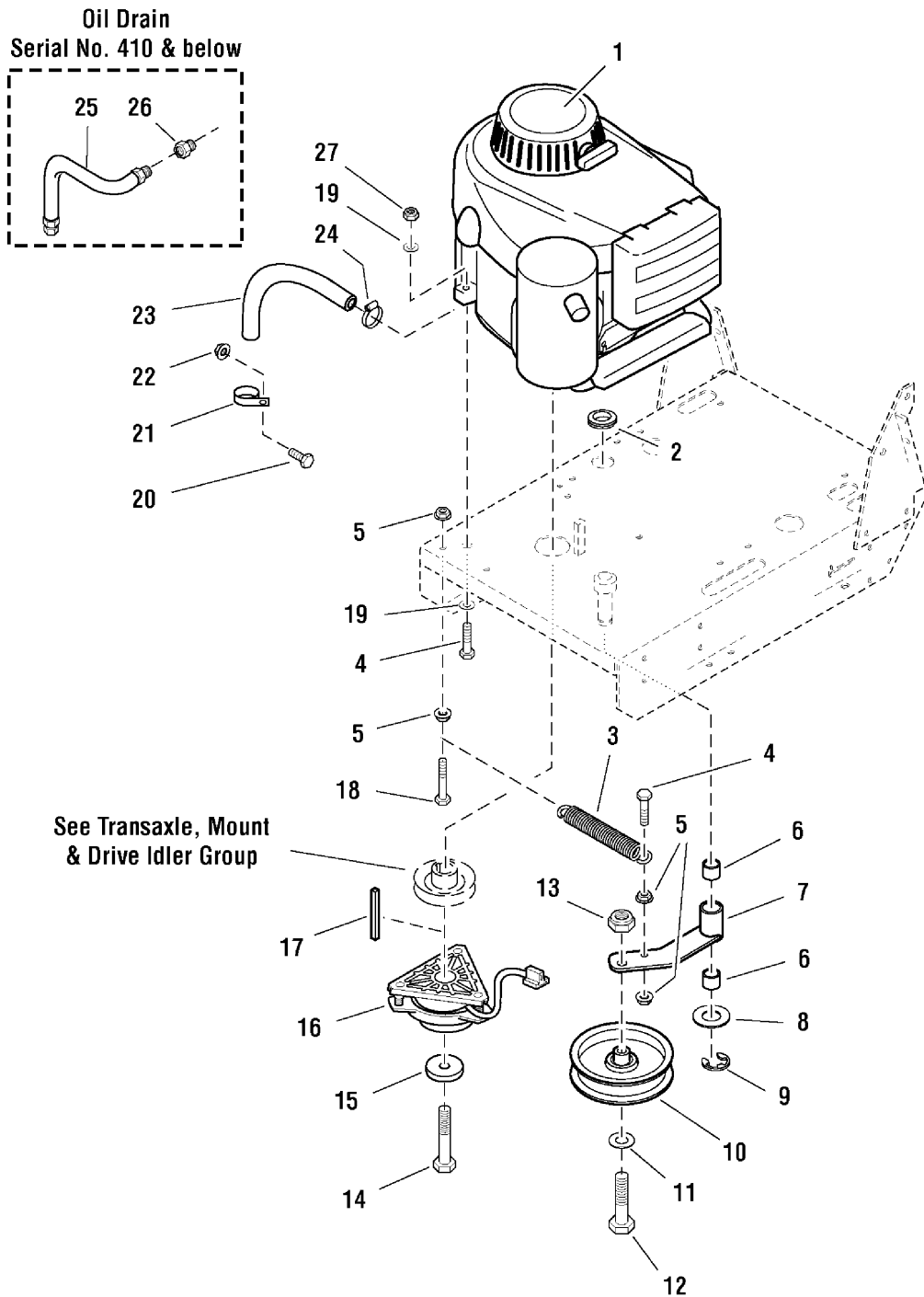

The above parts group applies to the following Mfg. Nos.:
HC32KAV13

Engine, PTO & Deck Drive Idler Group - Manual Start

REF NO.	PART NO.	QTY.	DESCRIPTION
1	22907	1	ENGINE, 13HP Kawasaki (Model FH381V)
1	21178-3	1	FUEL FILTER
1	21334-1	1	OIL FILTER (49065-2078)
1	-	1	PRE-CLEANER (11013-7016)
1	-	1	AIR FILTER (11013-7017)
1	-	1	MUFFLER (49070-7002)
1	-	1	EXHAUST MANIFOLD (18088-7001)
1	-	1	MANIFOLD HEAT SHIELD (13271-7022)
1	-	2	EXHAUST MANIFOLD GASKET (11060-7021)
1	-	1	RECOIL ASSEMBLY, Complete (49088-7001)
2	21379	1	GROMMET, 7/8"
3	21103	1	SPRING, Extension
4	25011-12	5	BOLT, 5/16-18 x 1-1/2
5	25139	4	NUT, 5/16-18 Hex Large Serrated Flange
6	20876B	2	BUSHING, Brass
7	47661	1	DECK DRIVE IDLER ARM
8	25160	1	WASHER, 3/4" SAE
9	20863	1	C-CLIP
10	21369	1	IDLER PULLEY
11	25158	1	WASHER, 1/2" SAE
12	25018-20	1	BOLT, 1/2-20 x 2-1/2
13	25098	1	NUT, 1/2-20 Hex Nylon Lock
14	47632	1	CRANKSHAFT BOLT, 7/16 x 2-3/4
15	42132	1	SPACER, .45 x 1.62 x .37
16	1717664	1	ELECTRIC CLUTCH
17	50407-3	1	KEY, 1/4 SQ. X 2
18	25011-18	1	BOLT, 5/16-18 x 2-1/4
19	25155	5	WASHER, 5/16" SAE
20	25011-6	1	BOLT, 5/16-18 x 3/4
21	23173	1	CLAMP
22	25127	1	NUT, 5/16-18 Hex Small Serrated Flange
23	50857-10.5	1	HOSE, 10-1/2"
24	21392	1	CLAMP, #6 Hose
25	48681	1	OIL DRAIN HOSE (S/N: 101-410)
26	22234	1	ADAPTER, Oil Drain (S/N: 101-410)
27	25057	4	NUT, 5/16-18 Hex Nylon Lock

Footnotes

- See your local Kawasaki engine dealer for parts & service.

The above parts group applies to the following Mfg. Nos.:

HC32KAV13

Engine, PTO & Deck Drive Idler Group - Electric Start

077engw1

NOTE: Unless noted otherwise,
use the standard hardware torque
specification chart.

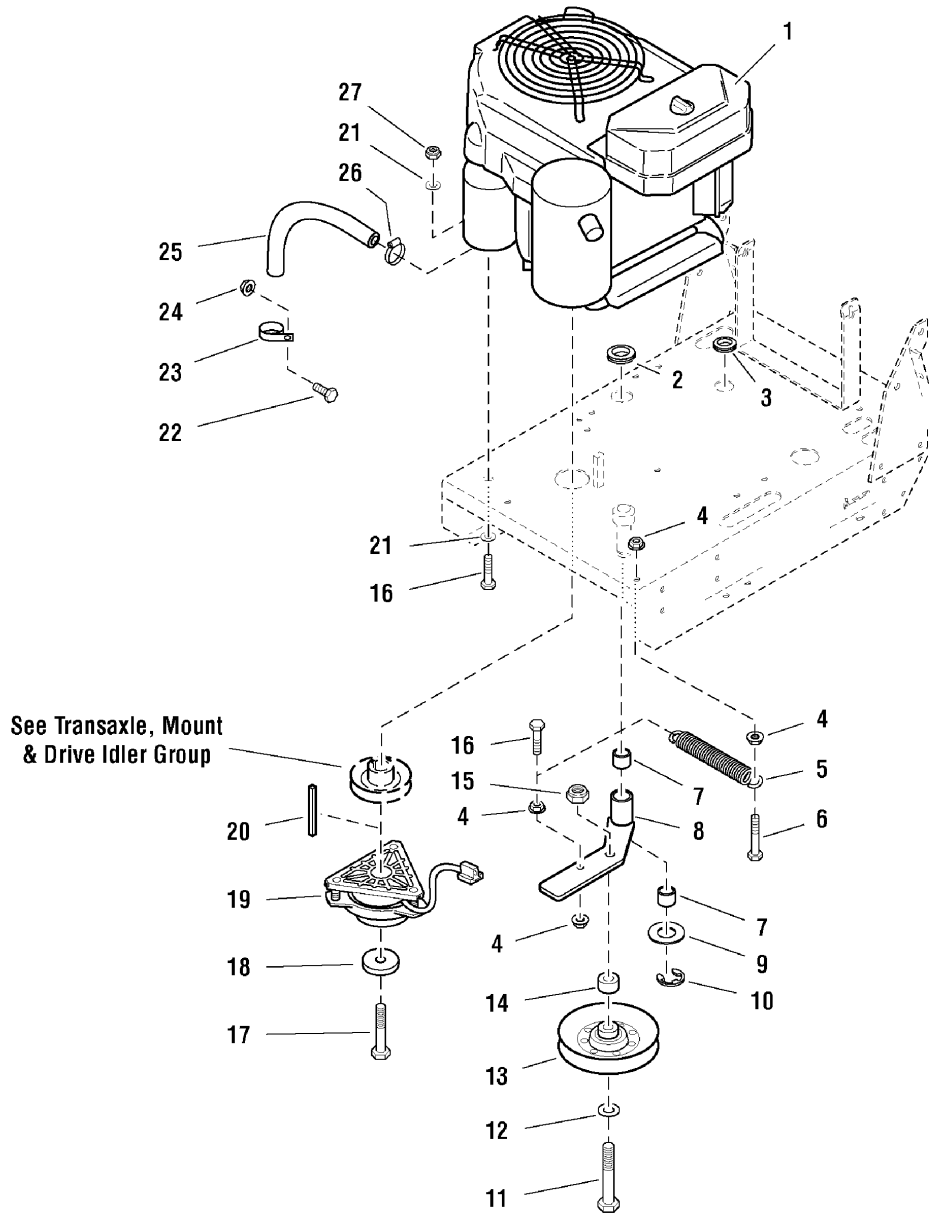

The above parts group applies to the following Mfg. Nos.:

HC36KAV13E
5900604

Engine, PTO & Deck Drive Idler Group - Electric Start

REF NO.	PART NO.	QTY.	DESCRIPTION
1	23399	1	ENGINE, 13HP Kawasaki (Model FH381V)
2	21379	1	GROMMET, 7/8"
3	21077	1	GROMMET, 1/2"
4	25139	4	NUT, 5/16-18 Hex Large Serrated Flange
5	23400	1	SPRING, Extension
6	25011-18	1	BOLT, 5/16-18 x 2-1/4
7	20876B	2	BUSHING, Brass
8	49208	1	DECK DRIVE IDLER ARM
9	25160	1	WASHER, 3/4" SAE
10	20863	1	C-CLIP
11	25017-22	1	BOLT, 1/2-13 x 2-3/4
12	25158	1	WASHER, 1/2" SAE
13	21097	1	PULLEY, V-Idler
14	49220	1	SPACER, .52 x 1.00 x .38
15	25056	1	NUT, 1/2-13 Hex Nylon Lock
16	25011-12	5	BOLT, 5/16-18 x 1-1/2
17	47632	1	CRANKSHAFT BOLT, 7/16 x 2-3/4
18	42132	1	SPACER, .45 x 1.62 x .37
19	1717664	1	ELECTRIC CLUTCH
20	50407-3	1	KEY, 1/4 SQ. X 2
21	25155	5	WASHER, 5/16" SAE
22	25011-6	1	BOLT, 5/16-18 x 3/4
23	23173	1	CLAMP
24	25127	1	NUT, 5/16-18 Hex Small Serrated Flange
25	50857-10.5	1	HOSE, 10-1/2"
26	21392	1	CLAMP, #6 Hose
27	25057	4	NUT, 5/16-18 Hex Nylon Lock

Footnotes

- See your local Kawasaki engine dealer for parts & service.

The above parts group applies to the following Mfg. Nos.:

HC36KAV13E
5900604

Motion Control, Parking Brake & Operator Presence Group - Electric Start

077mcge0

NOTE: Unless noted otherwise,
use the standard hardware torque
specification chart.

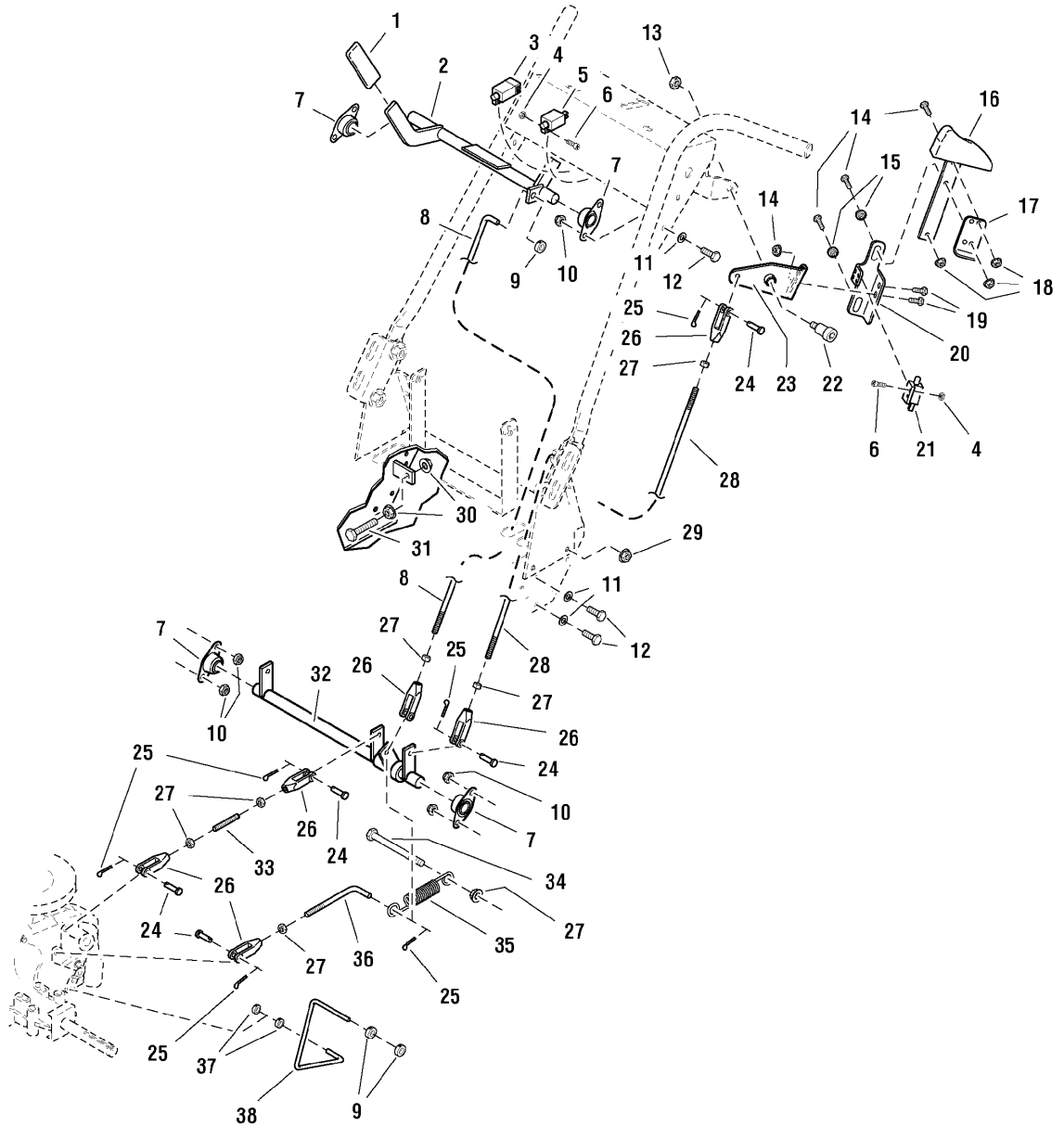

The above parts group applies to the following Mfg. Nos.:

HC36KAV13E
5900604

Motion Control, Parking Brake & Operator Presence Group - Electric Start

REF NO.	PART NO.	QTY.	DESCRIPTION
1	25510	1	FOAM GRIP
2	61278	1	BRAKE HANDLE SHAFT ASSEMBLY
3	22438	1	SWITCH, Plunger, NO/NO
4	25029	8	NUT, #10-24 Hex
5	21769	1	SWITCH, Plunger, NC
6	25179-4	8	SCREW, #10-24 x 1/2
7	21098	4	BEARING, Flange
8	61495	1	BRAKE ROD
9	20047	3	COLLAR, 5/16" Set
10	25057	8	NUT, 5/16-18 Hex Nylon Lock
11	25155	8	WASHER, 5/16" SAE
12	25011-6	8	BOLT, 5/16-18 x 3/4
13	25100	2	NUT, 3/8-16 Hex Side Lock
14	25010-8	6	BOLT, 1/4-20 x 1
15	61693	4	SLIDE SPACER
16	61691	1	CONTROL HANDLE, LH
16	61702	1	CONTROL HANDLE, RH (Not Shown)
17	61713	2	SWITCH ACTUATOR
18	25126	10	NUT, 1/4-20 Hex Serrated Flange
19	25010-6	4	BOLT, 1/4-20 x 3/4
20	61689	1	HANDLE MOUNT, LH
20	61692	1	HANDLE MOUNT, RH (Not Shown)
21	21769	2	SWITCH, Plunger, NC
22	25223	2	SHOULDER BOLT, 1/2 x 1
23	61683	1	PIVOT CONTROL, LH
23	61685	1	PIVOT CONTROL, RH (Not Shown)
24	25213-8	7	CLEVIS PIN, 5/16 x 1
25	25201-6	8	COTTER PIN, 3/32" x 3/4"
26	20979	8	CLEVIS, 5/16-24, Plastic
27	25033	8	NUT, 5/16-24 Hex
28	47642	2	THUMB CONTROL ROD
29	25128	2	NUT, 3/8-16 Hex Serrated Flange
30	25127	2	NUT, 5/16-18 Hex Small Serrated Flange
31	25055-14	1	BOLT, 5/16-18 x 1-3/4 TFL
32	47697	1	CONTROL SHAFT ASSEMBLY
33	47740	1	LINK STUD
34	25013-32	1	BOLT, 3/8-16 x 4
35	49352	1	SPRING, Extension
36	48328	1	BRAKE LINKAGE ROD
37	22481	2	COLLAR, Set, 1/4"
38	47732	1	DUMP VALVE ROD

Footnotes

The above parts group applies to the following Mfg. Nos.:

HC36KAV13E
5900604

Motion Control, Parking Brake & Operator Presence Group - Manual Start

077MCGM0

NOTE: Unless noted otherwise,
use the standard hardware torque
specification chart.

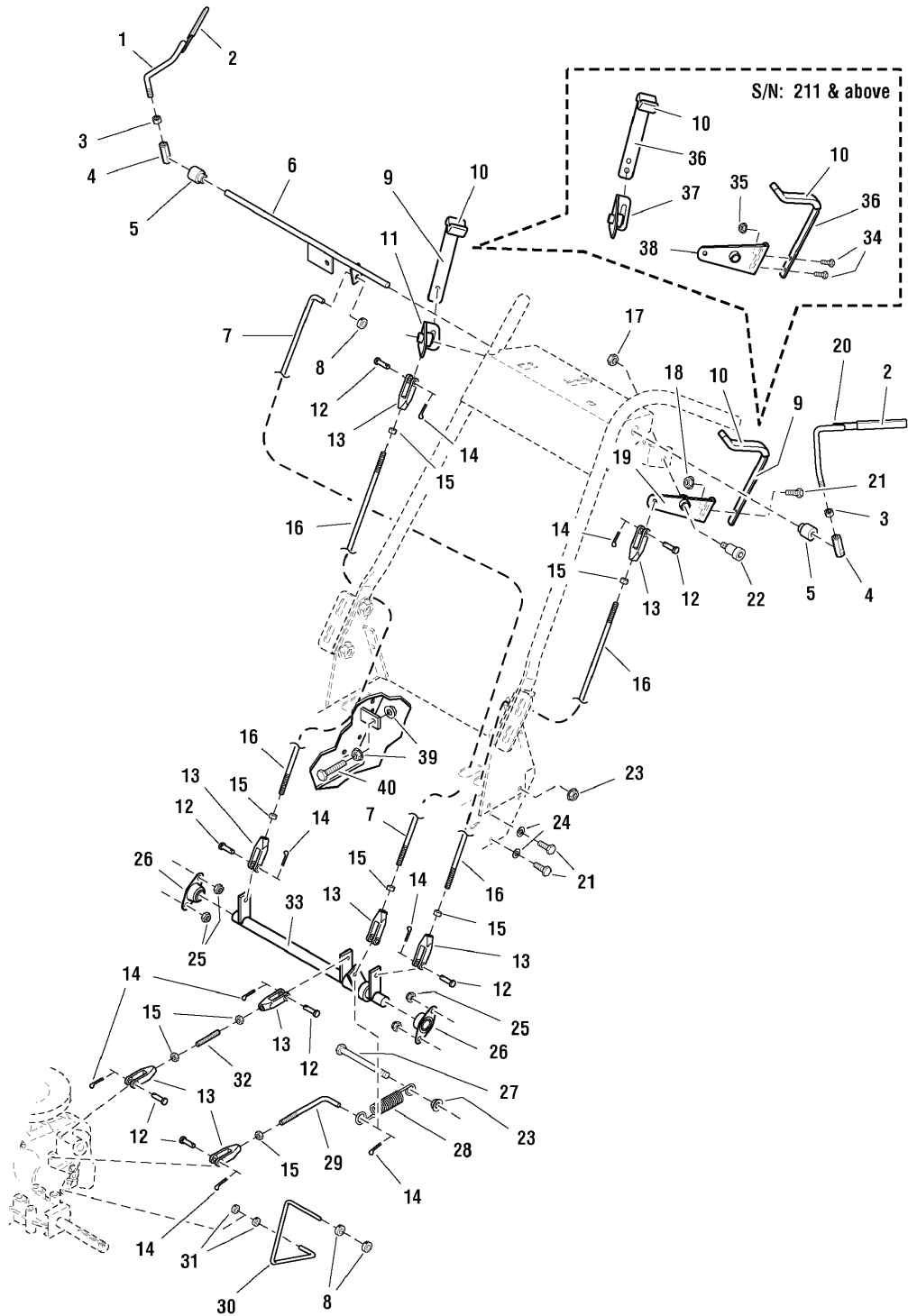

The above parts group applies to the following Mfg. Nos.:
HC32KAV13

Motion Control, Parking Brake & Operator Presence Group - Manual Start

REF NO.	PART NO.	QTY.	DESCRIPTION
1	49175	1	OPERATOR PRESENCE HANDLE - RH
2	21490	2	GRIP, Vinyl
3	25034	2	NUT, 3/8-16 Hex
4	43417	2	HEX ADJUSTER
5	45943	2	SHOULDER SPACER
6	47723	1	SWITCH ROD
7	48327	1	BRAKE ROD
8	20047	3	COLLAR, 5/16" Set
9	42614	2	THUMB CONTROL LEVER, Complete (Includes Ref No. 10 - S/N: 210 & below)
10	25510	2	FOAM GRIP
11	42542	1	PIVOT CONTROL - RH (S/N: 210 & below)
12	25213-8	7	CLEVIS PIN, 5/16 x 1
13	20979	8	CLEVIS, 5/16-24, Plastic
14	25201-6	8	COTTER PIN, 3/32" x 3/4"
15	25033	8	NUT, 5/16-24 Hex
16	47642	2	THUMB CONTROL ROD
17	25100	2	NUT, 3/8-16 Hex Side Lock
18	25139	2	NUT, 5/16-18 Hex Large Serrated Flange
19	42541	1	PIVOT CONTROL - LH (S/N: 210 & below)
20	49176	1	OPERATOR PRESENCE HANDLE - LH
21	25011-6	6	BOLT, 5/16-18 x 3/4
22	25223	2	SHOULDER BOLT, 1/2 x 1
23	25128	2	NUT, 3/8-16 Hex Serrated Flange
24	25155	4	WASHER, 5/16" SAE
25	25057	4	NUT, 5/16-18 Hex Nylon Lock
26	21098	2	BEARING, Flange
27	25013-32	1	BOLT, 3/8-16 x 4
28	49352	1	SPRING, Extension
29	48328	1	BRAKE LINKAGE ROD
30	47732	1	DUMP VALVE ROD
31	22481	2	COLLAR, Set, 1/4"
32	47740	1	LINK STUD
33	47697	1	CONTROL SHAFT ASSEMBLY
34	25010-6	4	BOLT, 1/4-20 x 3/4
35	25126	4	NUT, 1/4-20 Hex Serrated Flange
36	48547	2	THUMB CONTROL LEVER, Complete (Includes Ref No. 10 - S/N: 211 & above)
37	48544	1	PIVOT CONTROL - RH (S/N: 211 & above)
38	48545	1	PIVOT CONTROL - LH (S/N: 211 & above)
39	25127	2	NUT, 5/16-18 Hex Small Serrated Flange (S/N: 1039 & above)
40	25055-14	1	BOLT, 5/16-18 x 1-3/4 TFL (S/N: 1039 & above)

Footnotes

The above parts group applies to the following Mfg. Nos.:

HC32KAV13

Transaxle & Mount Group

NOTE: Unless noted otherwise,
use the standard hardware torque
specification chart.

077TRN0

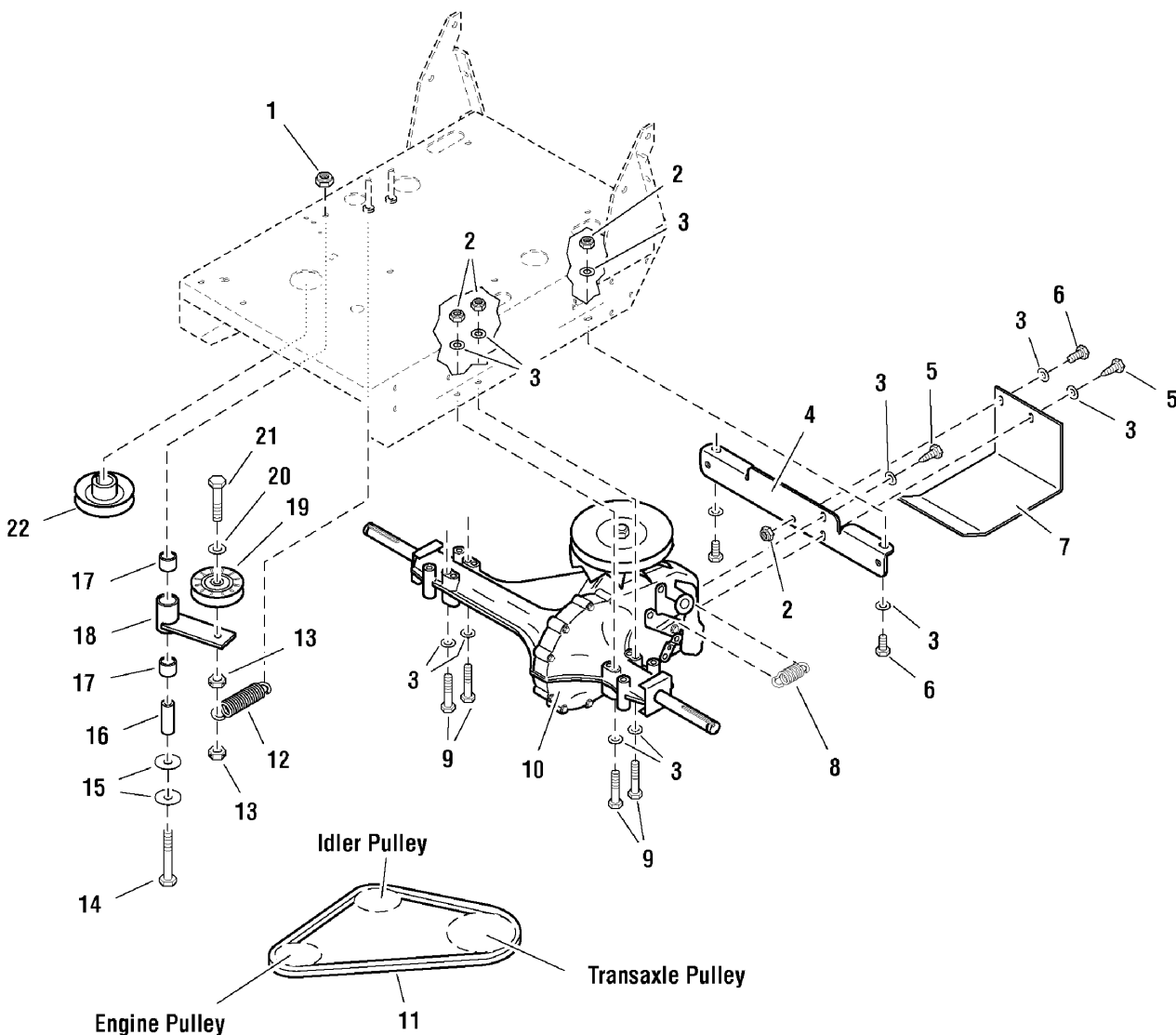

The above parts group applies to the following Mfg. Nos.:

- 5900604
- HC36KAV13E
- HC32KAV13

Transaxle & Mount Group

REF NO.	PART NO.	QTY.	DESCRIPTION
1	25096	1	NUT, 3/8-16 Hex Nylon Lock
2	25057	7	NUT, 5/16-18 Hex Nylon Lock
3	25155	12	WASHER, 5/16" SAE
4	47582	1	TRANSAXLE BRACE
5	25059-6	2	BOLT, Self-Tapping, 5/16-18 x 3/4
6	25011-6	3	BOLT, 5/16-18 x 3/4
7	48312	1	SKID PLATE
8	22967	1	HYDRO RETURN SPRING
9	25011-24	4	BOLT, 5/16-18 x 3
10	22905	1	HYDROSTATIC TRANSAXLE
11	23058	1	BELT
12	20807	1	SPRING, Extension
13	25100	2	NUT, 3/8-16 Hex Side Lock
14	25013-24	1	BOLT, 3/8-16 x 3
15	25165	2	WASHER, 3/8" Fender
16	47716	1	SPACER, .41 x .75 x 2.06
17	20876B	2	BUSHING, Brass
18	47717	1	TRANSAXLE IDLER ARM
19	43627	1	IDLER PULLEY
20	25156	1	WASHER, 3/8" SAE
21	25013-16	1	BOLT, 3/8-16 x 2
22	47914	1	TRANSAXLE DRIVE PULLEY

Footnotes

The above parts group applies to the following Mfg. Nos.:

5900604
HC36KAV13E
HC32KAV13

Transaxle - SERVICE PARTS

NOTE: Unless noted otherwise,
use the standard hardware torque
specification chart.

077TSP0

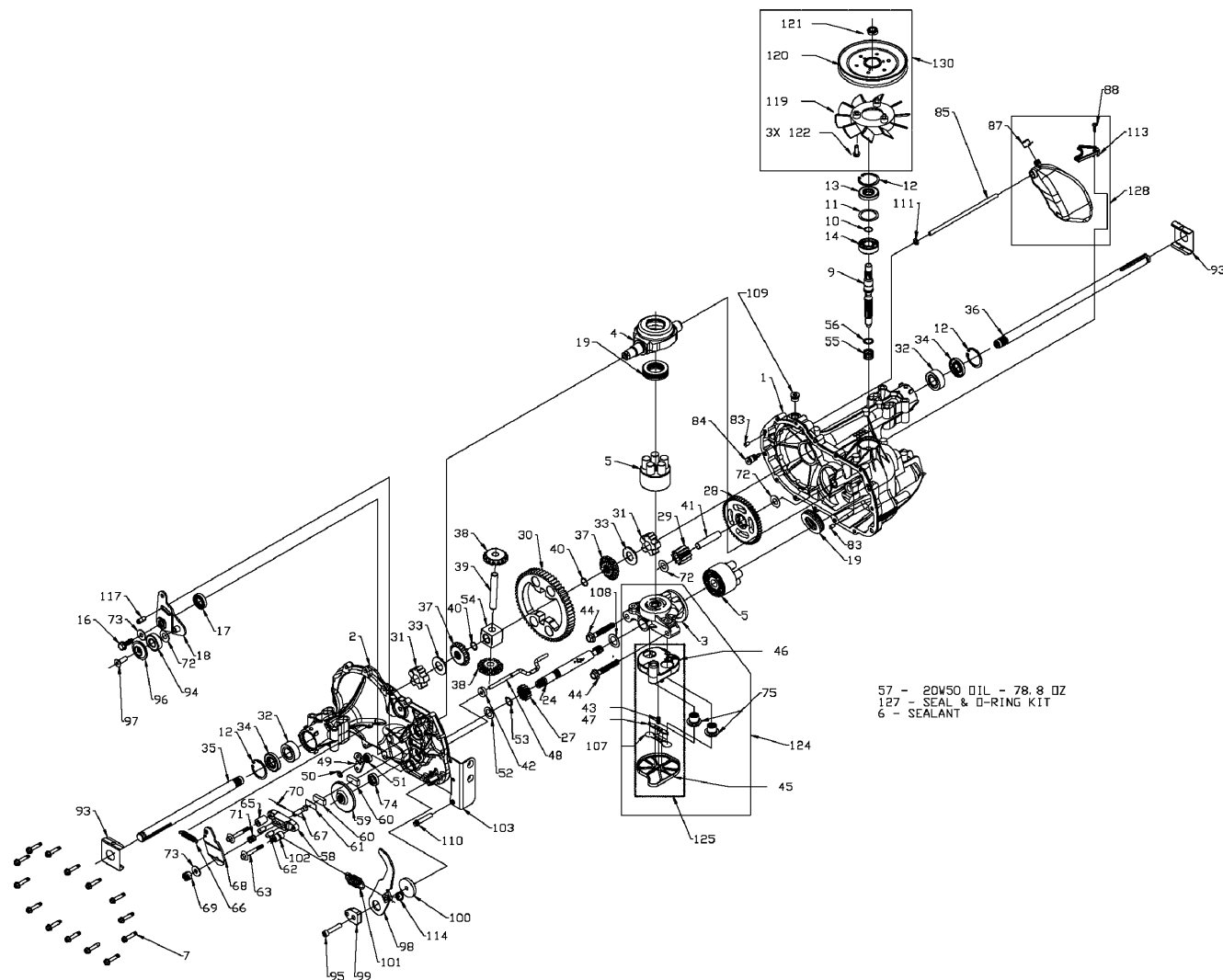

The above parts group applies to the following Mfg. Nos.:

HC36KAV13E

5900604

HC32KAV13

Transaxle - SERVICE PARTS

REF NO.	PART NO.	QTY.	DESCRIPTION
6	22905-1	10.5	SEALANT
9	22905-2	1	SHAFT, INPUT
10	22905-3	1	RING - RETAINING
11	22905-4	1	SPACER
12	22905-5	3	RING - RETAINING
13	22905-16	1	SEAL, Lip, .67 x 1.58 x .276
14	22905-6	1	BALL BEARING
32	22905-7	2	OUTBOARD SLEEVE BEARING
34	22905-17	2	LIP SEAL, Axle Seal
35	22905-8	1	AXLE SHAFT - RH
36	22905-9	1	AXLE SHAFT - LH
55	22905-10	1	SPRING - HELICAL COMPRESSION
56	22905-11	1	WASHER
57	22905-12	78.8	20W-50 OIL
101	22967	1	HYDRO RETURN SPRING
119	22905-13	1	FAN, 6", 10 BLADE
128	22905-14	1	EXPANSION TANK KIT
130	22905-15	1	FAN/PULLEY KIT (Includes Ref. No. 119)

Footnotes

The above parts group applies to the following Mfg. Nos.:

HC36KAV13E

5900604

HC32KAV13

Tire & Wheel Group

NOTE: Unless noted otherwise,
use the standard hardware torque
specification chart.

077WHL0

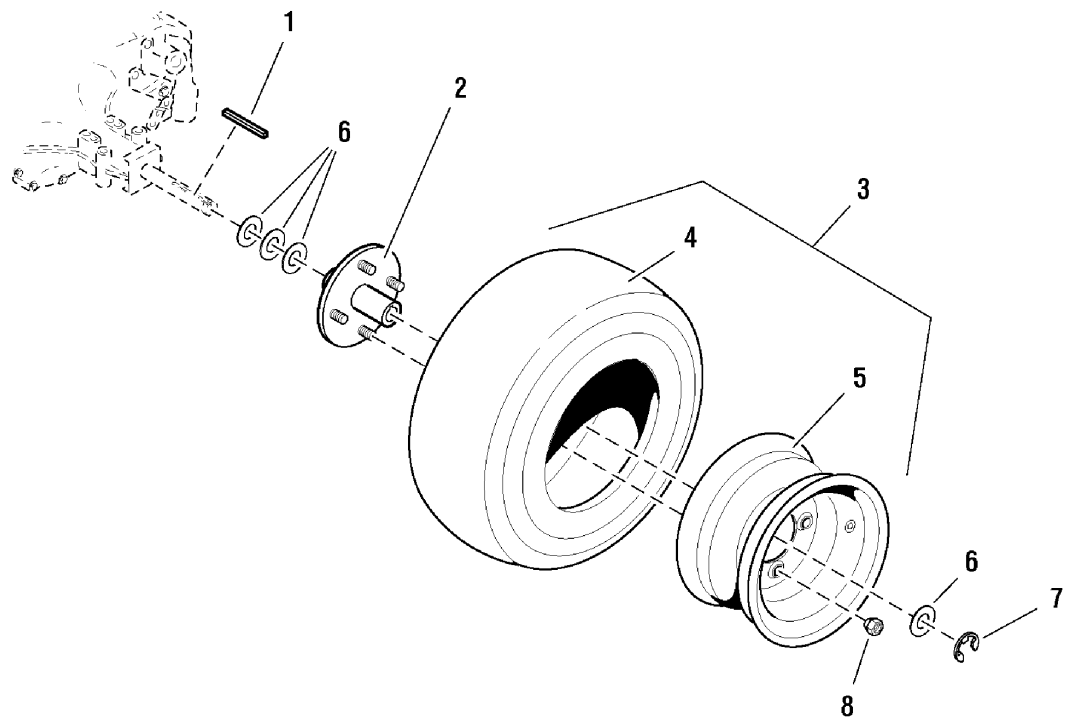

The above parts group applies to the following Mfg. Nos.:

HC32KAV13
HC36KAV13E
5900604

Tire & Wheel Group

REF NO.	PART NO.	QTY.	DESCRIPTION
1	48409	2	KEY, 3/16 SQ. X 2-1/2
2	20792S	2	DRIVE HUB
3	23104	2	WHEEL & TIRE ASSEMBLY, 16 x 6.5 x 8, Complete (Includes Ref No. 4 & 5)
4	23104-2	2	TIRE, 16. x 6.5 x 8
5	23104-1	2	WHEEL ASSEMBLY, 8 x 5.38
6	25520-3	8	SHIM
7	20863	2	C-CLIP
8	20601	8	LUG NUT, 1/2-20

Footnotes

The above parts group applies to the following Mfg. Nos.:

HC32KAV13
HC36KAV13E
5900604

Decals - Brand & Model

077dc1b0

NOTE: Unless noted otherwise,
use the standard hardware torque
specification chart.

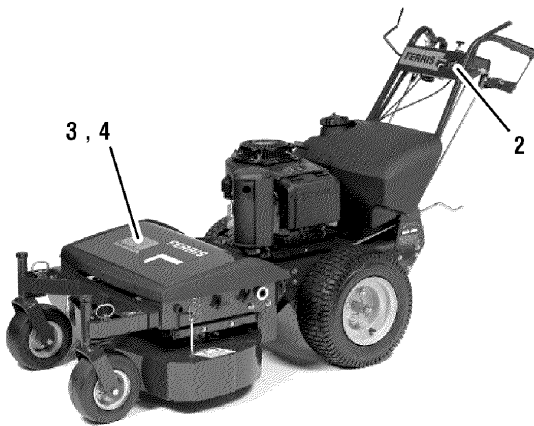
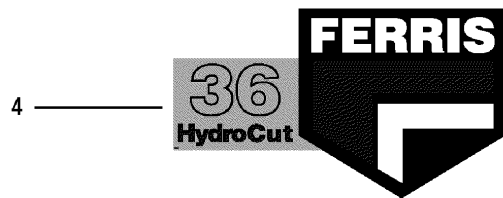
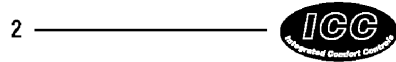
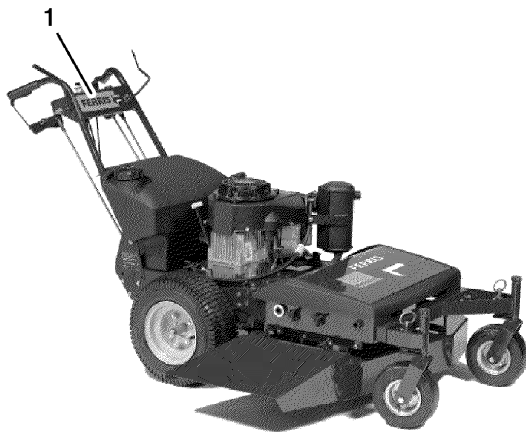

The above parts group applies to the following Mfg. Nos.:

HC32KAV13
HC36KAV13E
5900604

Decals - Brand & Model

REF NO.	PART NO.	QTY.	DESCRIPTION
1	22560	1	DECAL, Ferris Text Logo
2	48228	1	DECAL, ICC
3	48229	1	DECAL, HydroCut 32
4	49065	1	DECAL, HydroCut 36

Footnotes

The above parts group applies to the following Mfg. Nos.:

HC32KAV13
HC36KAV13E
5900604

Decals - Safety & Instruction

REF NO.	PART NO.	QTY.	DESCRIPTION
1	48321	1	DECAL, Control Panel (Manual Start)
2	61465	1	DECAL, Control Panel (Electric Start)
3	49318	1	DECAL, Height Of Cut (32" model)
4	49021	1	DECAL, Height Of Cut (36" model)
5	47778	1	DECAL, Cut Height Adjust
6	61537	1	DECAL, Belt R&R (36" model)
7	1704473	1	DECAL, Hot Surface
8	49658	1	DECAL, Danger
9	21818	1	DECAL, Warning, Machine Will Climb
10	1704277	1	DECAL, Danger (Chute In Place)
11	1704276	2	DECAL, Danger (Hand Under Deck)

Footnotes

The above parts group applies to the following Mfg. Nos.:

HC32KAV13
HC36KAV13E
5900604

32" Mower Deck - Frame, Caster & Shield

REF NO.	PART NO.	QTY.	DESCRIPTION
1	48145	1	SHIELD INSERT
2	25299-4	4	SCREW, Allen Head, 1/4-20 x 1/2
3	48150	1	GUARD, MOWER HOUSING
4	48353	2	SHIELD MOUNT BRACKET
5	22308	4	BODY CLIP, 5/16-18
6	25169	4	WASHER, 1/4" Lock
7	25010-6	4	BOLT, 1/4-20 x 3/4
8	25013-8	8	BOLT, 3/8-16 x 1
9	25128	8	NUT, 3/8-16 Hex Serrated Flange
10	25013-20	4	BOLT, 3/8-16 x 2-1/2
11	25156	4	WASHER, 3/8" SAE
12	22319	4	KNOB
13	47648	1	FRAME RAIL - LH
14	22098	2	CAP, Plastic
15	48194	1	CROSS TUBE
16	48969	1	CASTER MOUNT FRAME, Complete (Includes Ref No. 17 & 28)
17	20095	2	GREASE FITTING
18	25017-44	2	BOLT, 1/2-13 x 5-1/2
19	41657	2	AXLE, Caster Wheel
20	21181S	2	WHEEL & TIRE ASSEMBLY, Silver, 9 x 3.5 x 4, Complete (Includes Ref No. 21 - 25)
21	21181-1	2	TIRE, Front, 9 x 3.5 x 4
22	21181-2	2	TUBE
23	21181S-3	2	HUB & BEARING ASSEMBLY, Complete, Silver (Includes Ref No. 24 & 25)
24	21182	2	BEARING, Roller (1 per tire)
25	21043	4	RETAINER, Bearing (2 per tire)
26	25056	2	NUT, 1/2-13 Hex Nylon Lock
27	48172	2	CASTER YOKE (Use with Ref No. 16, part no. 48969)
28	20823	4	BUSHING, Flange
29	25096	4	NUT, 3/8-16 Hex Nylon Lock
30	10114	2	COLLAR, 3/4" Split
31	47649	1	FRAME RAIL - RH
32	48968	1	CASTER MOUNT FRAME W/ LOCKS, Complete (Includes Ref No. 17 & 28)
33	48965	2	CASTER YOKE (Use with Ref No. 32, part no. 48968)
34	23274	2	VINYL CAP

Footnotes

The above parts group applies to the following Mfg. Nos.:

HC32KAV13
5900604

32" Mower Deck - Height Adjustment

0772HA0

NOTE: Unless noted otherwise,
use the standard hardware torque
specification chart.

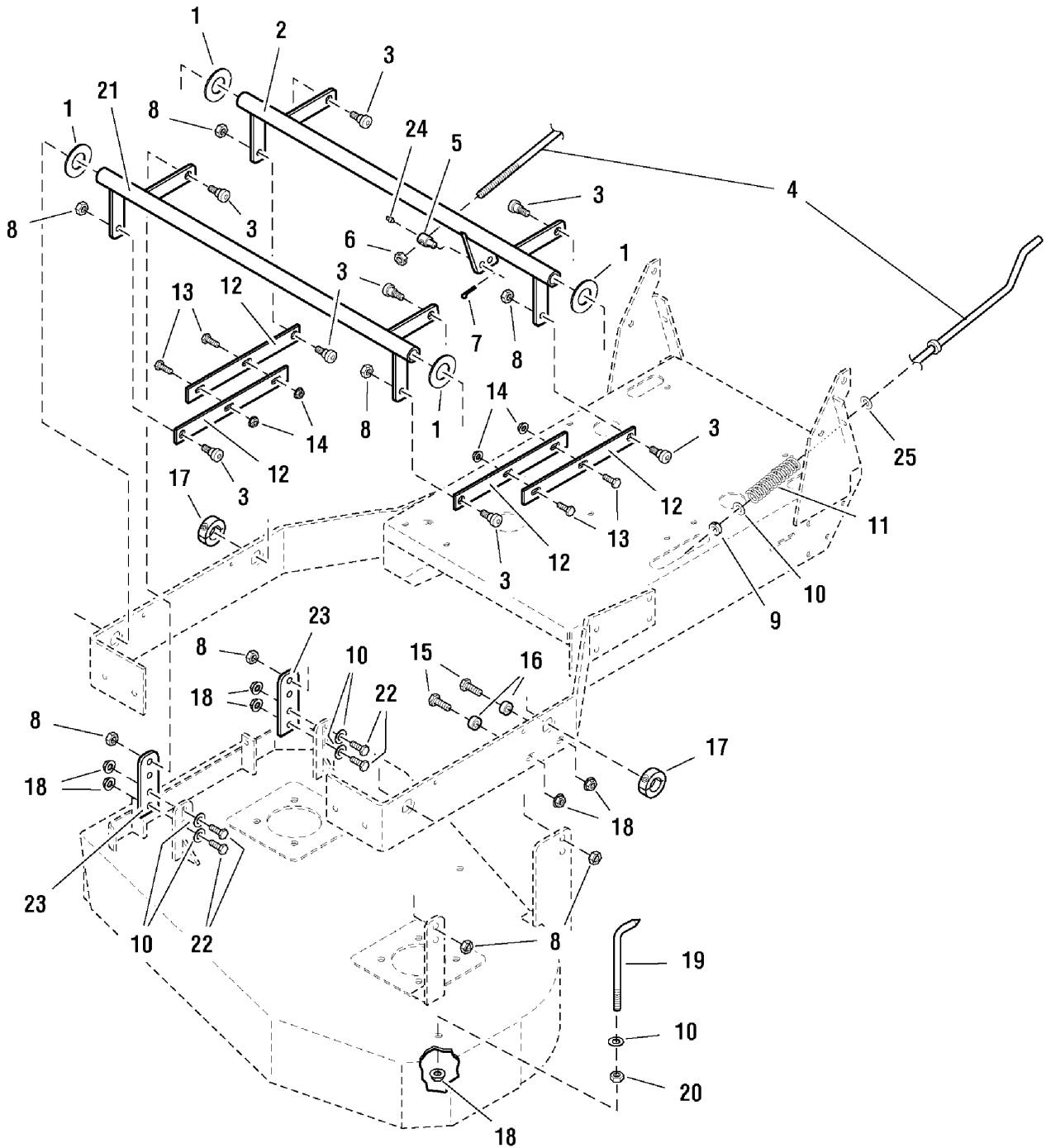

The above parts group applies to the following Mfg. Nos.:

HC32KAV13
5900604

32" Mower Deck - Height Adjustment

REF NO.	PART NO.	QTY.	DESCRIPTION
1	25162	4	WASHER, 1" SAE
2	47682	1	DECK LIFT PIVOT - REAR
3	25356	8	SHOULDER BOLT, 1/2 x 3/8
4	47655	1	HEIGHT ADJUST ROD
5	48526	1	LINKAGE ADJUSTER
6	25100	1	NUT, 3/8-16 Hex Side Lock
7	25201-6	1	COTTER PIN, 3/32" x 3/4"
8	25046	8	NUT, 3/8-16 Hex Top Lock
9	10546	1	COLLAR, 3/8" Set
10	25156	6	WASHER, 3/8" SAE
11	22645	1	SPRING, Compression
12	47710	4	DECK ADJUST LINK
13	25011-8	4	BOLT, 5/16-18 x 1
14	25139	4	NUT, 5/16-18 Hex Large Serrated Flange
15	25013-10	2	BOLT, 3/8-16 x 1-1/4
16	44933	2	SPACER, .39 x .75 x .38
17	48549	2	COLLAR, Double Split, 1"
18	25128	7	NUT, 3/8-16 Hex Serrated Flange
19	47737	1	CUT HEIGHT INDICATOR
20	25034	1	NUT, 3/8-16 Hex
21	47681	1	DECK LIFT PIVOT - FRONT
22	25013-6	4	BOLT, 3/8-16 x 3/4
23	48439	2	HANGER PLATE
24	20095	1	GREASE FITTING
25	48548	1	WASHER, Nylon, 3/8

Footnotes

The above parts group applies to the following Mfg. Nos.:

HC32KAV13
5900604

32" Mower Deck - Housing, Spindles, Blades & Pulleys

0772HC0

NOTE: Unless noted otherwise,
use the standard hardware torque
specification chart.

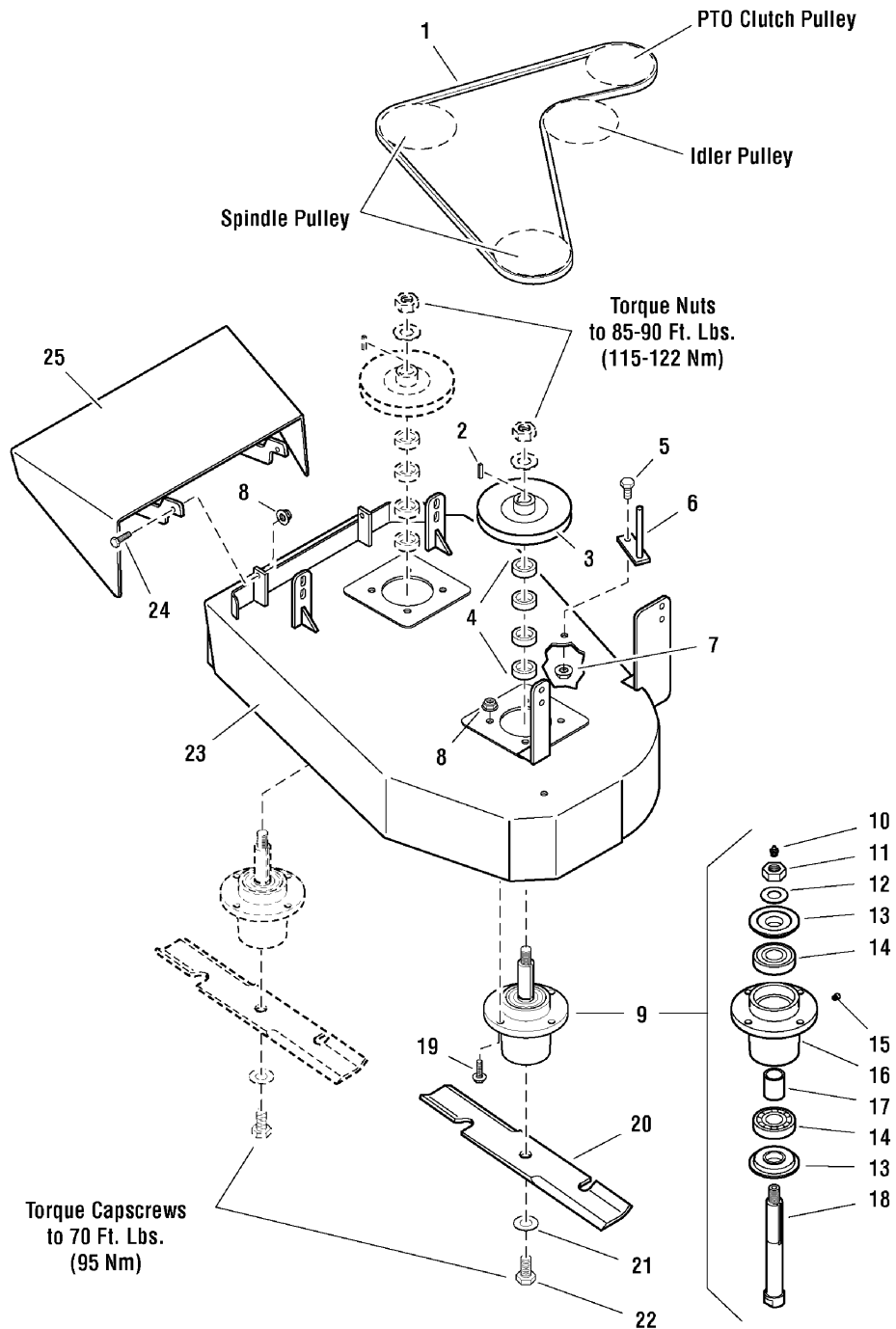

The above parts group applies to the following Mfg. Nos.:

HC32KAV13
5900604

32" Mower Deck - Housing, Spindles, Blades & Pulleys

REF NO.	PART NO.	QTY.	DESCRIPTION
1	22918	1	BELT
2	50407-1	2	KEY, 1/4 SQ. X 1
3	47638	2	SPINDLE PULLEY
4	47725	8	SPACER
5	25013-8	1	BOLT, 3/8-16 x 1
6	47777	1	BELT GUIDE
7	25126	1	NUT, 1/4-20 Hex Serrated Flange
8	25392	10	NUT, 5/16-18 Hex Nylock Flange
9	61096	2	SPINDLE ASSEMBLY, Complete (Includes Ref No. 10 - 18)
10	23329	2	GREASE FITTING
11	25405	2	NUT, 3/4-16 Hex
12	25406	2	WASHER, 3/4" Belleville
13	49793	4	TRASH SHIELD
14	23330	4	BEARING
15	23296	2	RELIEF VALVE
16	61097	2	SPINDLE HOUSING
17	61099	2	SPACER, 1.00 x 1.25 x 1.75
18	61100	2	SPINDLE SHAFT
19	23156	8	BOLT, Flange Head, 5/16-18 x 1-1/4
20	20843	2	MOWER BLADE, 16-1/4"
21	25159	2	WASHER, 5/8" USS
22	25320-14	2	BOLT, 5/8-11 x 1-3/4
23	6647576	1	32" MOWER HOUSING ASSEMBLY (Includes safety decals)
24	25011-8	2	BOLT, 5/16-18 x 1
25	47724	1	DISCHARGE CHUTE

Footnotes

The above parts group applies to the following Mfg. Nos.:

HC32KAV13
5900604

36" Mower Deck - Frame, Caster & Shield

0773fr0

NOTE: Unless noted otherwise,
use the standard hardware torque
specification chart.

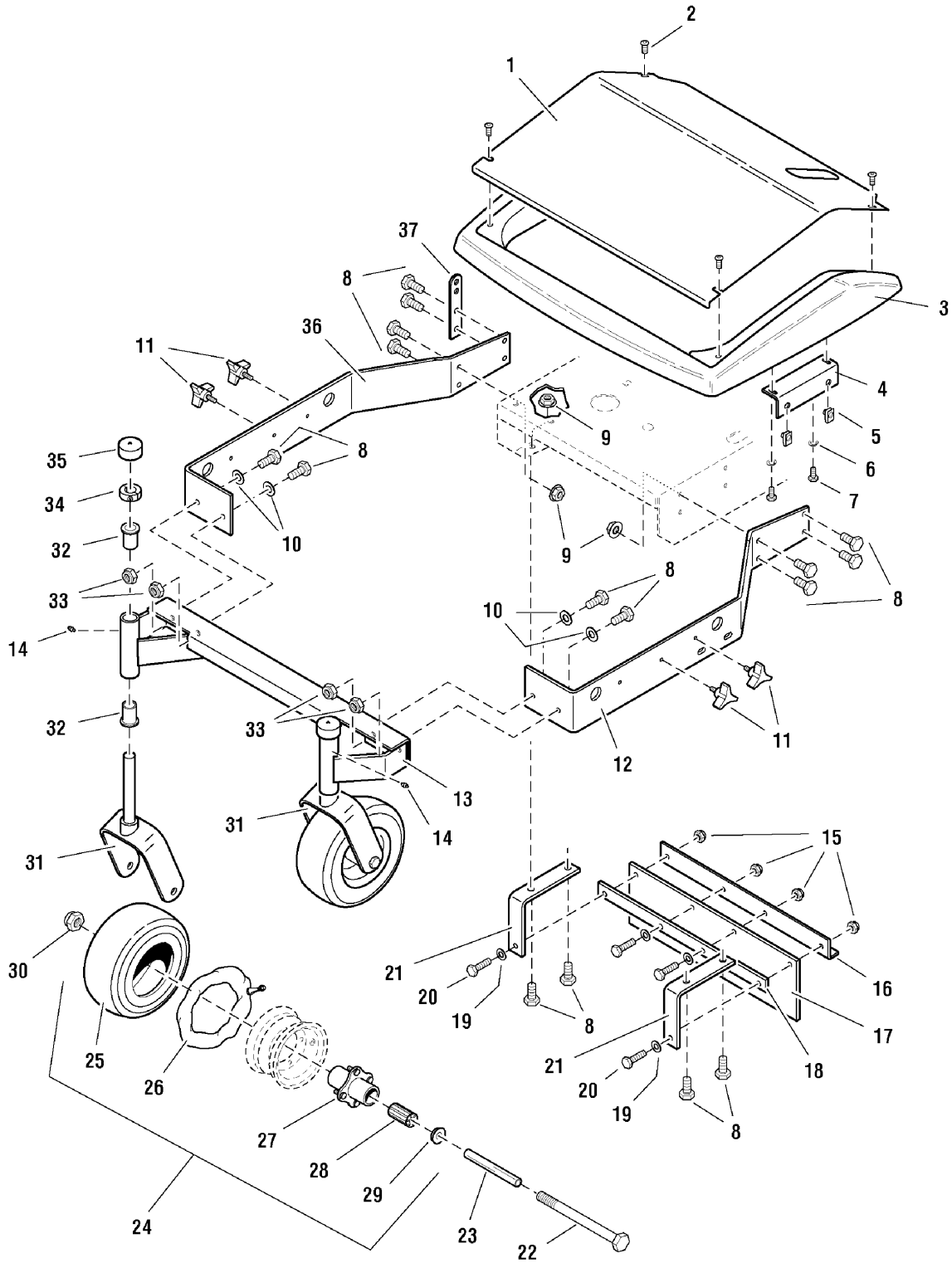

The above parts group applies to the following Mfg. Nos.:
HC36KAV13E

36" Mower Deck - Frame, Caster & Shield

REF NO.	PART NO.	QTY.	DESCRIPTION
1	48145	1	SHIELD INSERT
2	25299-4	4	SCREW, Allen Head, 1/4-20 x 1/2
3	48150	1	GUARD, Mower Deck
4	48353	2	SHIELD MOUNT BRACKET
5	22308	4	BODY CLIP, 5/16-18
6	25169	4	WASHER, 1/4" Lock
7	25010-6	4	BOLT, 1/4-20 x 3/4
8	25013-10	12	BOLT, 3/8-16 x 1-1/4
9	25128	8	NUT, 3/8-16 Hex Serrated Flange
10	25156	4	WASHER, 3/8" SAE
11	22319	4	KNOB
12	47648	1	FRAME RAIL - LH
13	49262	1	CASTER MOUNT FRAME, Complete (Includes Ref No. 14 & 32)
14	20095	2	GREASE FITTING
15	25095	4	NUT, 1/4-20 Hex Nylon Lock
16	49214	1	SHIELD MOUNT ANGLE
17	49217	1	RUBBER SHIELD
18	49216	1	SHIELD MOUNT BAR
19	25154	4	WASHER, 1/4" SAE
20	25010-10	4	BOLT, 1/4-20 X 1
21	49215	2	SHIELD MOUNT BRACKET
22	25017-44	2	BOLT, 1/2-13 x 5-1/2
23	41657	2	AXLE, Caster Wheel
24	21181S	2	WHEEL & TIRE ASSEMBLY, Silver, 9 x 3.5 x 4, Complete (Includes Ref No. 25 - 29)
25	21181-1	2	TIRE, Front, 9 x 3.5 x 4
26	21181-2	2	TUBE
27	21181S-3	2	HUB & BEARING ASSEMBLY, Complete, Silver (Includes Ref No. 28 & 29)
28	21182	2	BEARING, Roller (1 per tire)
29	21043	4	RETAINER, Bearing (2 per tire)
30	25056	2	NUT, 1/2-13 Hex Nylon Lock
31	48172	2	CASTER YOKE
32	20823	4	BUSHING, Flange
33	25096	4	NUT, 3/8-16 Hex Nylon Lock
34	10114	2	COLLAR, 3/4" Split
35	23274	2	VINYL CAP
36	47649	1	FRAME RAIL - RH
37	61717	1	WIRE GUARD

Footnotes

The above parts group applies to the following Mfg. Nos.:

HC36KAV13E

36" Mower Deck - Height Adjustment

NOTE: Unless noted otherwise,
use the standard hardware torque
specification chart.

0773ha0

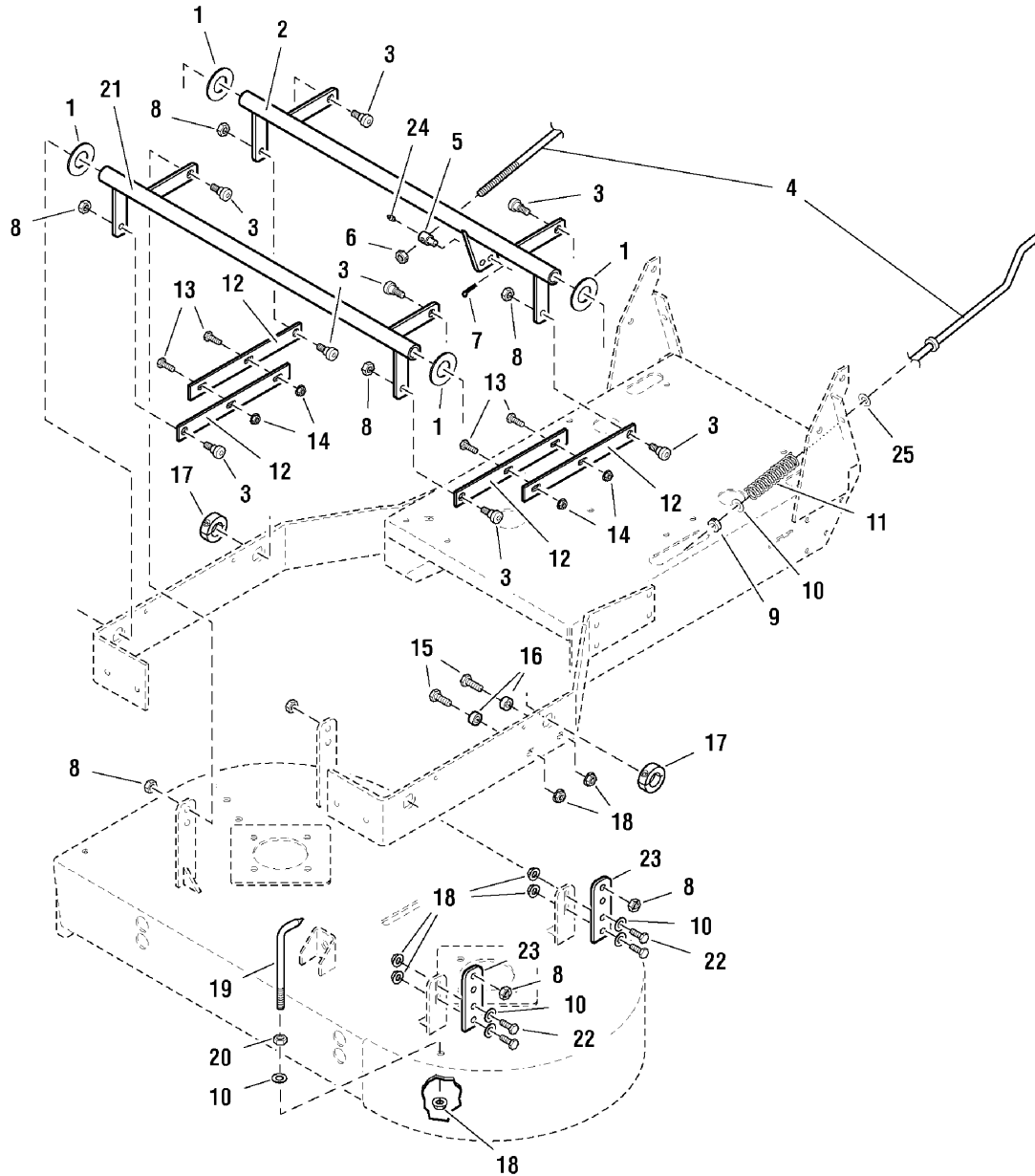

The above parts group applies to the following Mfg. Nos.:
HC36KAV13E

36" Mower Deck - Height Adjustment

REF NO.	PART NO.	QTY.	DESCRIPTION
1	25162	4	WASHER, 1" SAE
2	47682	1	DECK LIFT PIVOT - REAR
3	25356	8	SHOULDER BOLT, 1/2 x 3/8
4	47655	1	HEIGHT ADJUST ROD
5	48526	1	LINKAGE ADJUSTER
6	25100	1	NUT, 3/8-16 Hex Side Lock
7	25201-6	1	COTTER PIN, 3/32" x 3/4"
8	25046	8	NUT, 3/8-16 Hex Top Lock
9	10546	1	COLLAR, 3/8" Set
10	25156	6	WASHER, 3/8" SAE
11	22645	1	SPRING, Compression
12	47710	4	DECK ADJUST LINK
13	25011-8	4	BOLT, 5/16-18 x 1
14	25139	4	NUT, 5/16-18 Hex Large Serrated Flange
15	25013-10	2	BOLT, 3/8-16 x 1-1/4
16	44933	2	SPACER, .39 x .75 x .38
17	48549	2	COLLAR, Double Split, 1"
18	25128	7	NUT, 3/8-16 Hex Serrated Flange
19	47737	1	CUT HEIGHT INDICATOR
20	25034	1	NUT, 3/8-16 Hex
21	47681	1	DECK LIFT PIVOT - FRONT
22	25013-8	4	BOLT, 3/8-16 x 1
23	48439	2	HANGER PLATE
24	20095	1	GREASE FITTING
25	48548	1	WASHER, Nylon, 3/8

Footnotes

The above parts group applies to the following Mfg. Nos.:

HC36KAV13E

36" Mower Deck - Housing, Spindles, Blades & Pulleys

NOTE: Unless noted otherwise, use the standard hardware torque specification chart.

0773hc0

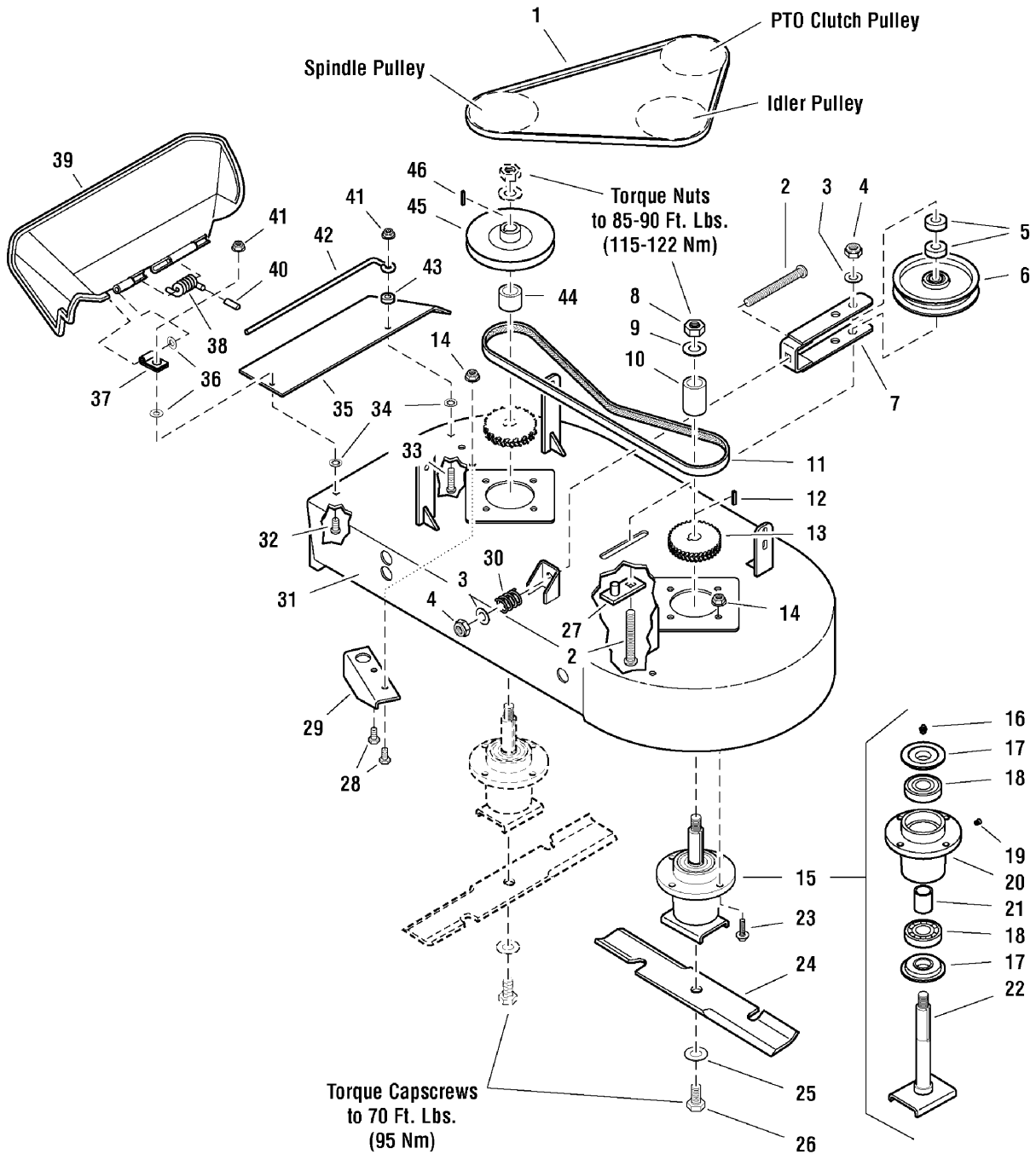

The above parts group applies to the following Mfg. Nos.:
HC36KAV13E

36" Mower Deck - Housing, Spindles, Blades & Pulleys

REF NO.	PART NO.	QTY.	DESCRIPTION
1	23262	1	BELT
2	25324-32	2	CARRIAGE BOLT, 1/2-13 x 4
3	25158	2	WASHER, 1/2" SAE
4	25056	2	NUT, 1/2-13 Hex Nylon Lock
5	45023	2	SPACER, .52 x 1.00 x .44
6	23264	1	IDLER PULLEY
7	48994	1	IDLER MOUNT
8	25405	2	NUT, 3/4-16 Hex
9	25406	2	WASHER, 3/4" Belleville
10	49218	1	SPACER, 1.00 x 1.57 x .69
11	49238	1	BELT, Chevron
12	25389	2	KEY, 1/4 SQ. X 3/4
13	48977	2	SPROCKET, Chevron
14	25392	8	NUT, 5/16-18 Hex Nylock Flange
15	61175	2	SPINDLE ASSEMBLY, Complete (Includes Ref No. 16 - 22)
16	23329	2	GREASE FITTING
17	49793	4	TRASH SHIELD
18	23330	4	BEARING
19	23296	2	RELIEF VALVE
20	61097	2	SPINDLE HOUSING
21	61099	2	SPACER, 1.00 x 1.25 x 1.75
22	61137	2	SPINDLE SHAFT w/ SADDLE
23	23156	8	BOLT, Flange Head, 5/16-18 x 1-1/4
24	21227	2	MOWER BLADE, 18"
25	25159	2	WASHER, 5/8" USS
26	25320-14	2	BOLT, 5/8-11 x 1-3/4
27	61727	1	PULLEY RETAINER
28	25011-6	2	BOLT, 5/16-18 x 3/4
29	48954	1	BAFFLE
30	22788	1	SPRING, Compression
31	48735	1	MOWER DECK HOUSING
32	25144-6	1	CARRIAGE BOLT, 1/4-20 x 3/4
33	25144	1	CARRIAGE BOLT, 1/4-20 x 1-1/4
34	1960518	2	PUSH NUT, 1/4, Black
35	61511	1	CHUTE SUPPORT PLATE
36	25154	2	WASHER, 1/4" SAE
37	1704873	1	CLAMP
38	1723938	1	SPRING, Torsion
39	1705449	1	DEFLECTOR
40	1723323	1	SPRING END CAP
41	25391	2	NUT, 1/4-20 Hex Nylock Flange

Footnotes

The above parts group applies to the following Mfg. Nos.:

HC36KAV13E

36" Mower Deck - Housing, Spindles, Blades & Pulleys

NOTE: Unless noted otherwise, use the standard hardware torque specification chart.

0773hc0

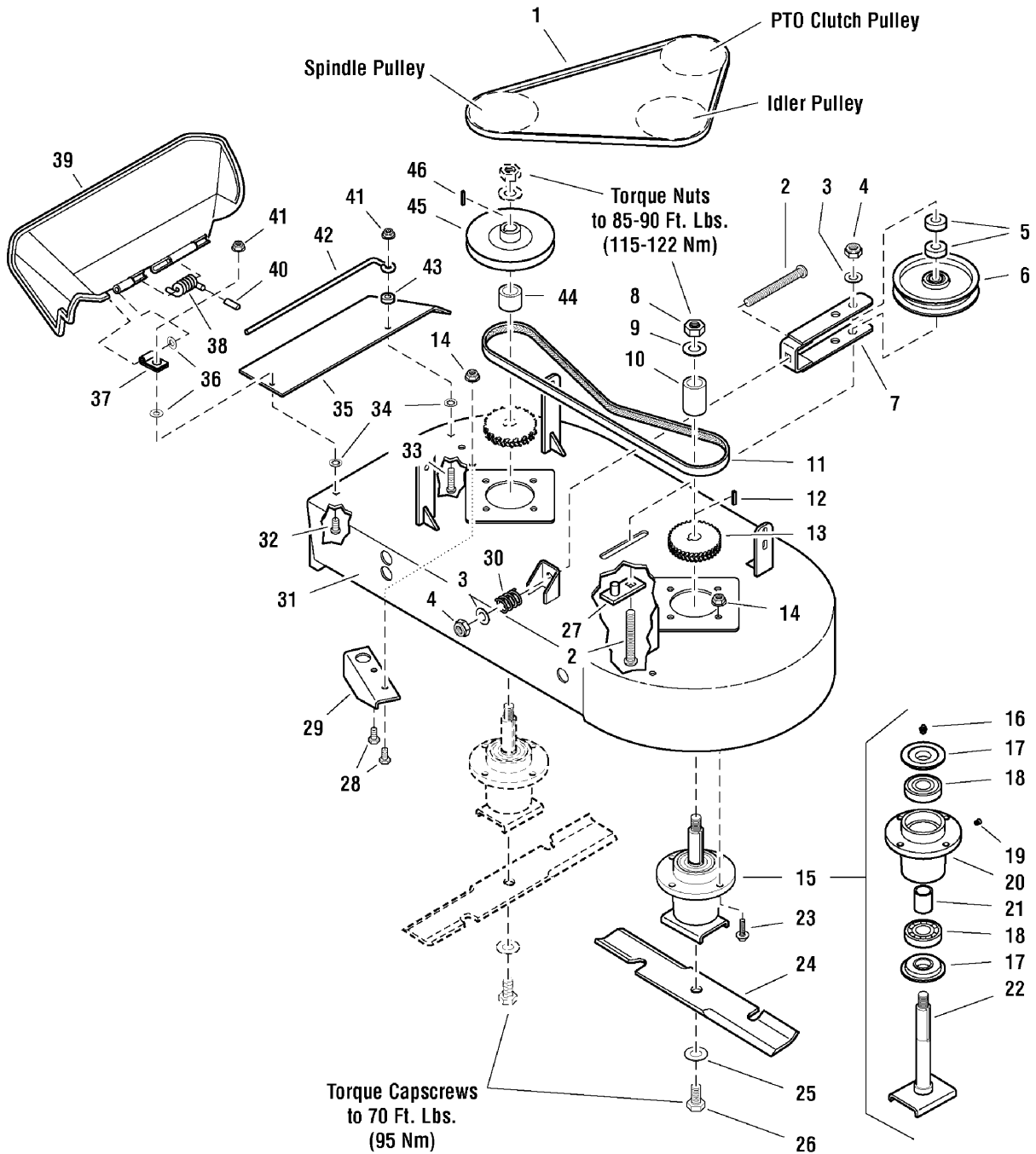

The above parts group applies to the following Mfg. Nos.:
HC36KAV13E

36" Mower Deck - Housing, Spindles, Blades & Pulleys

REF NO.	PART NO.	QTY.	DESCRIPTION
42	61807	1	CHUTE SUPPORT ROD
43	44933	1	SPACER, .39 x .75 x .38
44	49221	1	SPACER, 1.00 x 1.57 x 1.19
45	47638	1	SPINDLE PULLEY
46	50407-1	1	KEY, 1/4 SQ. X 1

Footnotes

The above parts group applies to the following Mfg. Nos.:

HC36KAV13E

Electrical Group - Electric Start

077egwe0

NOTE: Unless noted otherwise,
use the standard hardware torque
specification chart.

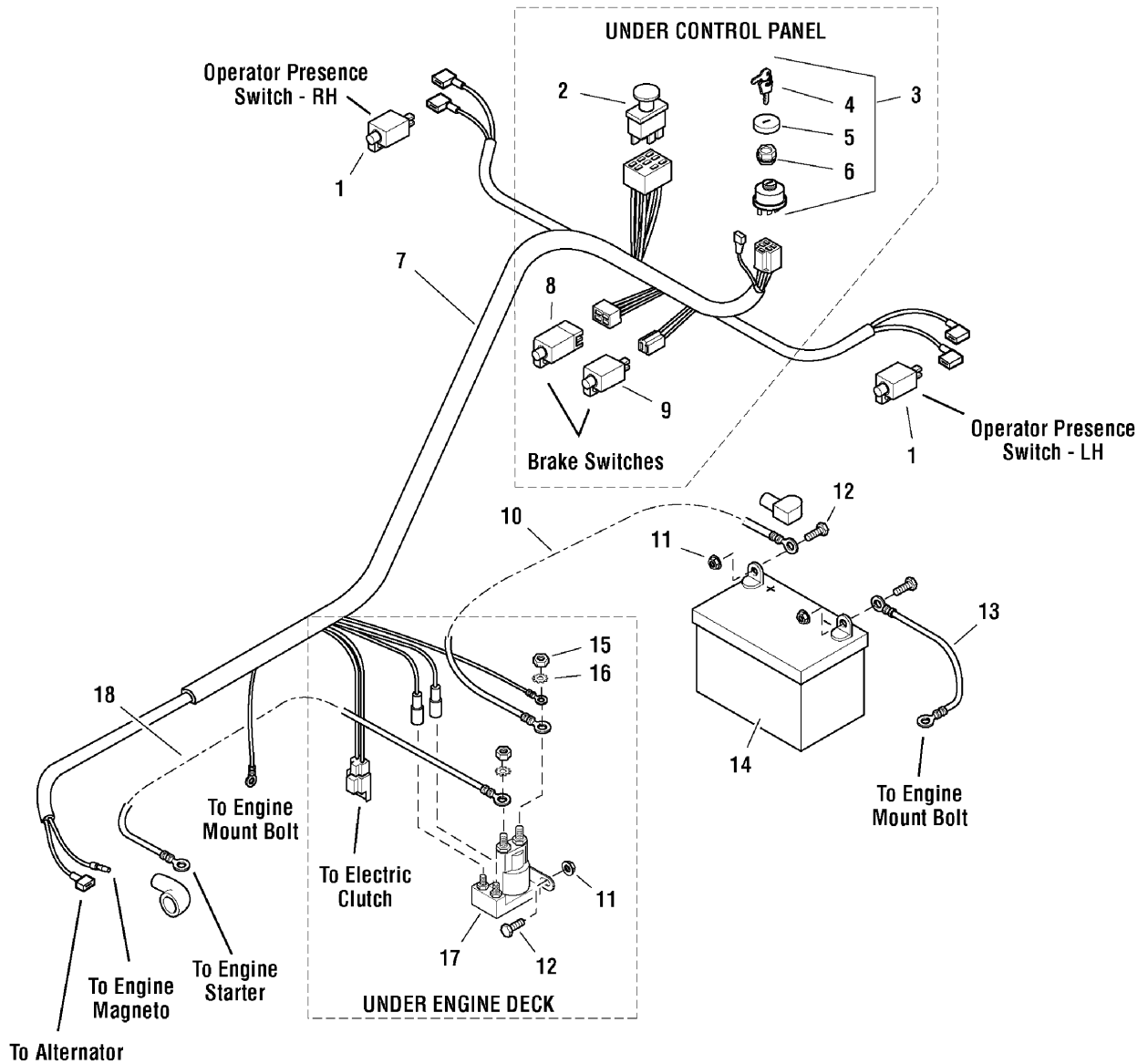

The above parts group applies to the following Mfg. Nos.:

5900604
HC36KAV13E

Electrical Group - Electric Start

REF NO.	PART NO.	QTY.	DESCRIPTION
1	61675	2	SWITCH, NC
2	22180	1	SWITCH, PTO
3	20927	1	SWITCH, Ignition, Complete (Includes Ref No. 4 - 6)
4	22789	1	KEY, Ignition, Molded Set
5	22790	1	COVER
6	22791	1	PLASTIC NUT
7	61470	1	WIRE HARNESS
8	22438	1	SWITCH, Plunger, NO/NO
9	21769	1	SWITCH, Plunger, NC
10	21405	1	POSITIVE (+) BATTERY CABLE, 22"
11	25126	4	NUT, 1/4-20 Hex Serrated Flange
12	25010-6	4	BOLT, 1/4-20 x 3/4
13	21406	1	NEGATIVE (-) BATTERY CABLE, 22"
14	-	1	BATTERY, Lawn & Garden, 12V (BCIU1, 340 CCA)
15	23216	2	NUT, Hex Jam, 5/16-24
16	23217	2	WASHER, Light Lock, 5/16
17	1724815	1	SOLENOID
18	21542	1	POSITIVE (+) BATTERY CABLE, 30"

Footnotes

The above parts group applies to the following Mfg. Nos.:

5900604
HC36KAV13E

Electrical Group - Manual Start

077EGWM0

NOTE: Unless noted otherwise,
use the standard hardware torque
specification chart.

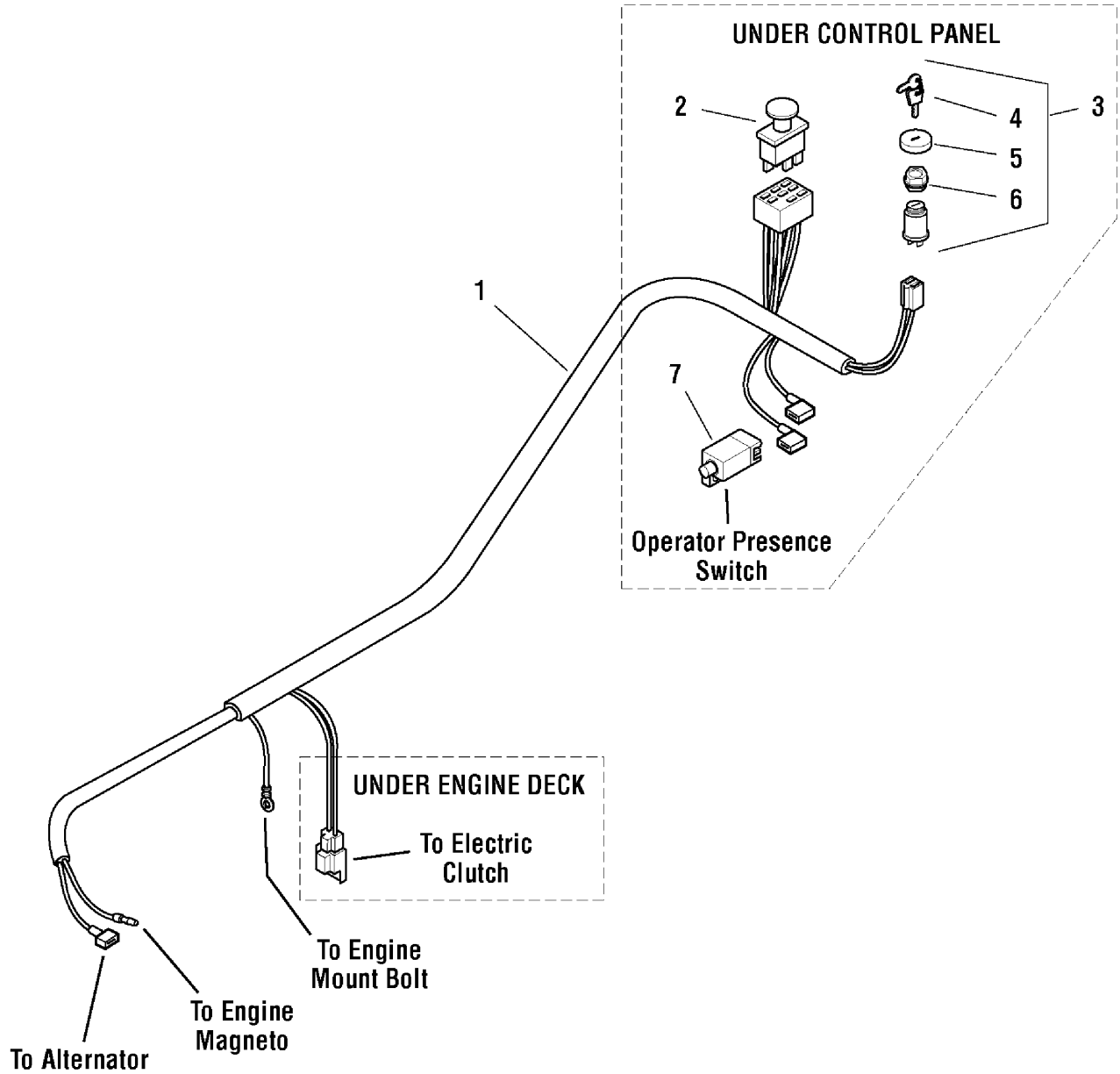

The above parts group applies to the following Mfg. Nos.:
HC32KAV13

Electrical Group - Manual Start

REF NO.	PART NO.	QTY.	DESCRIPTION
1	47772	1	WIRE HARNESS
2	22180	1	SWITCH, PTO
3	21842	1	SWITCH, Ignition, Complete (Includes Ref No. 4 - 6)
4	22789	1	KEY, Ignition, Molded Set
5	22790	1	COVER
6	22791	1	PLASTIC NUT
7	21769	1	SWITCH, Plunger, NC

Footnotes

The above parts group applies to the following Mfg. Nos.:

HC32KAV13

Serial No. 1038 & below

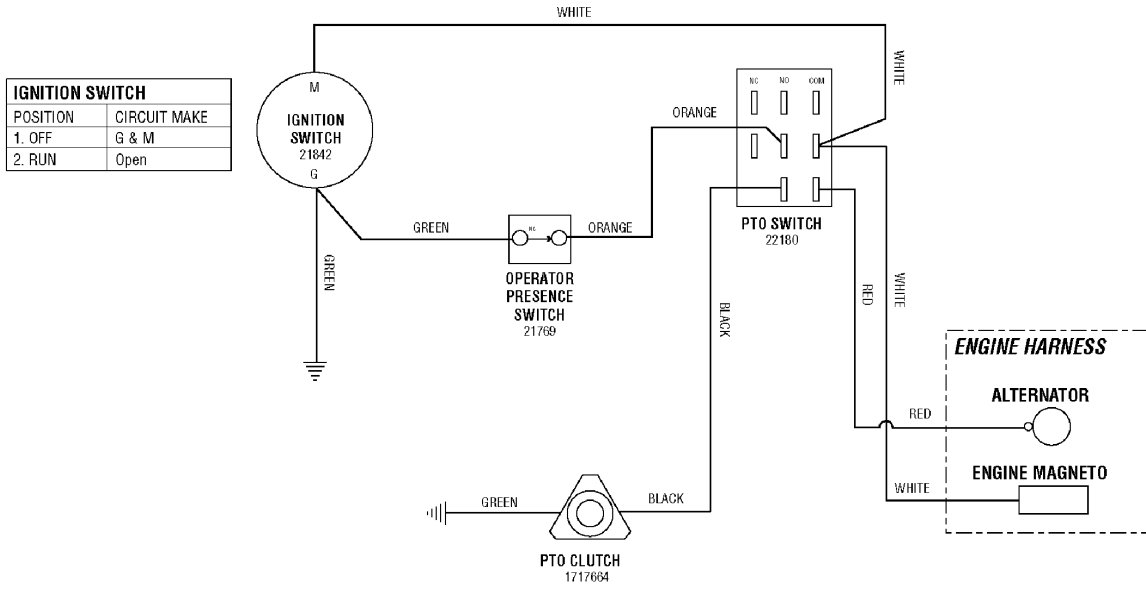

Serial No. 1039 & above

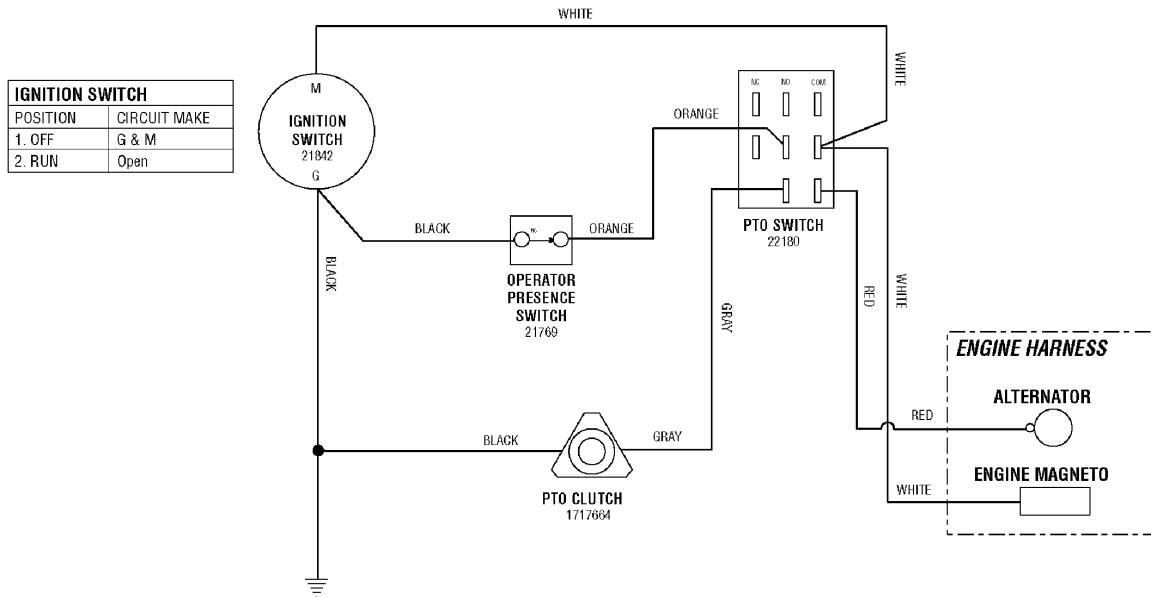

The above parts group applies to the following Mfg. Nos.:

HC32KAV13

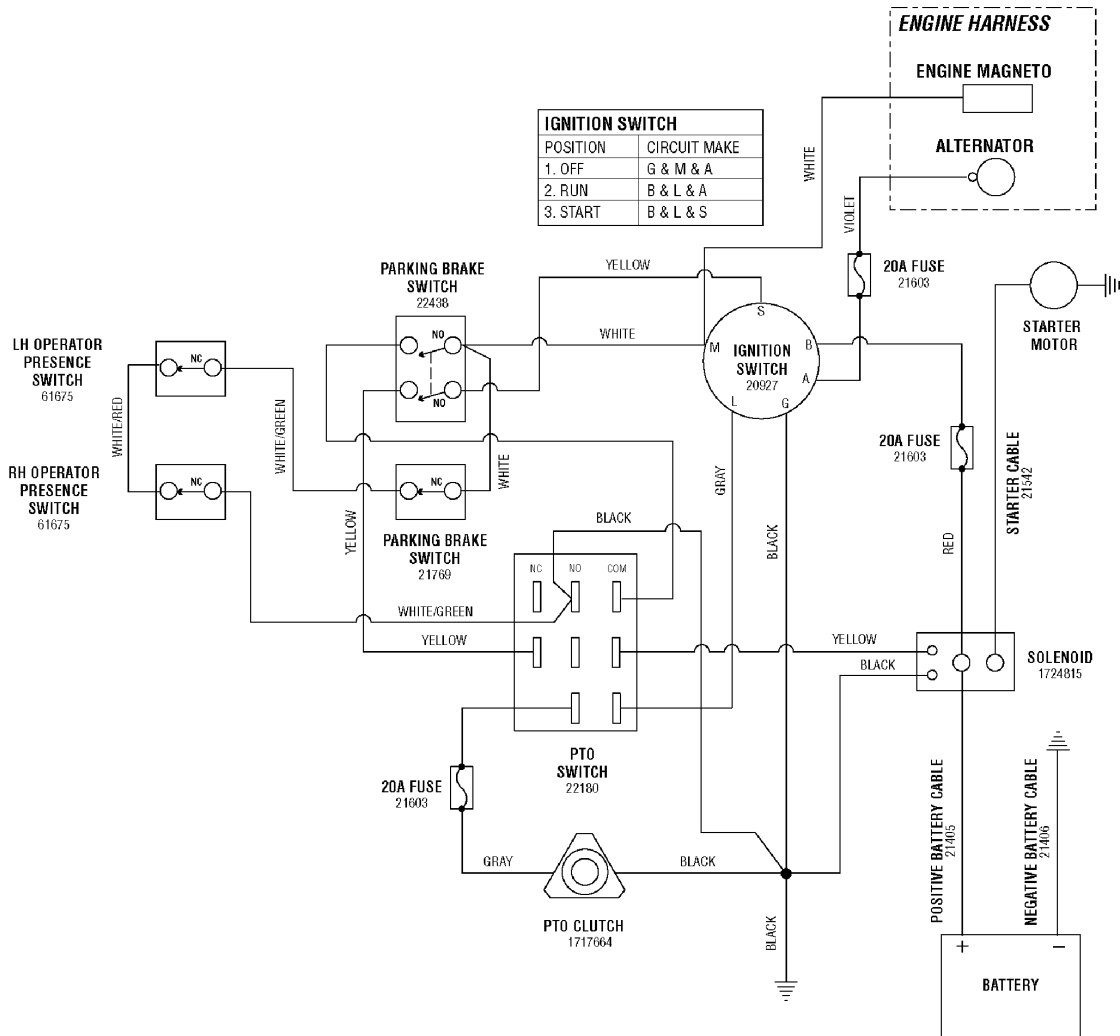

The above parts group applies to the following Mfg. Nos.:

HC36KAV13E
5900604

Hardware Identification & Torque Specifications

Common Hardware Types

Hex Head Capscrew

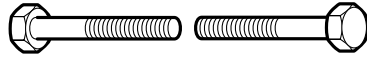

Washer



Lockwasher



Carriage Bolt



Hex Nut



Standard Hardware Sizing

When a washer or nut is identified as $1/2''$, this is the *Nominal size*, meaning the *inside diameter* is $1/2$ inch; if a second number is present it represents the *threads per inch*

When bolt or capscrew is identified as $1/2 - 16 \times 2''$, this means the *Nominal size*, or *body diameter* is $1/2$ inch; the second number represents the *threads per inch* (16 in this example, and the final number is the *body length* of the bolt or screw (in this example 2 inches long).

The guides and ruler furnished below are designed to help you select the appropriate hardware and tools.

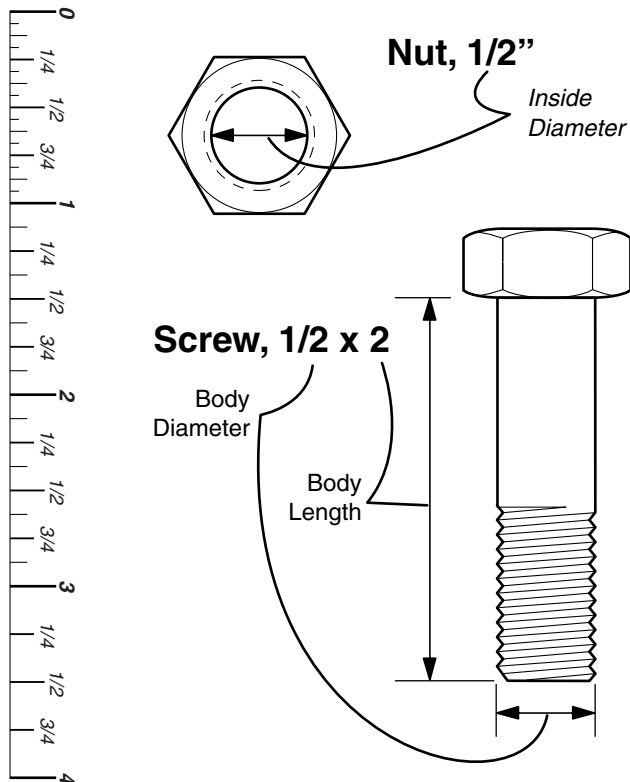

Torque Specification Chart

FOR STANDARD MACHINE HARDWARE (Tolerance $\pm 20\%$)

Hardware Grade	No Marks SAE Grade 2		SAE Grade 5		SAE Grade 8	
	in/lbs ft/lbs	Nm.	in/lbs ft/lbs	Nm.	in/lbs ft/lbs	Nm.
8-32	19	2.1	30	3.4	41	4.6
8-36	20	2.3	31	3.5	43	4.9
10-24	27	3.1	43	4.9	60	6.8
10-32	31	3.5	49	5.5	68	7.7
1/4-20	66	7.6	8	10.9	12	16.3
1/4-28	76	8.6	10	13.6	14	19.0
5/16-18	11	15.0	17	23.1	25	34.0
5/16-24	12	16.3	19	25.8	27	34.0
3/8-16	20	27.2	30	40.8	45	61.2
3/8-24	23	31.3	35	47.6	50	68.0
7/16-14	30	40.8	50	68.0	70	95.2
7/16-20	35	47.6	55	74.8	80	108.8
1/2-13	50	68.0	75	102.0	110	149.6
1/2-20	55	74.8	90	122.4	120	163.2
9/16-12	65	88.4	110	149.6	150	204.0
9/16-18	75	102.0	120	163.2	170	231.2
5/8-11	90	122.4	150	204.0	220	299.2
5/8-18	100	136	180	244.8	240	326.4
3/4-10	160	217.6	260	353.6	386	525.0
3/4-16	180	244.8	300	408.0	420	571.2
7/8-9	140	190.4	400	544.0	600	816.0
7/8-14	155	210.8	440	598.4	660	897.6
1-8	220	299.2	580	788.8	900	1,244.0
1-12	240	326.4	640	870.4	1,000	1,360.0

NOTES

- These torque values are to be used for all hardware excluding: locknuts, self-tapping screws, thread forming screws, sheet metal screws and socket head setscrews.
- Recommended seating torque values for locknuts:
 - for prevailing torque locknuts - use 65% of grade 5 torques.
 - for flange whizlock nuts and screws - use 135% of grade 5 torques.
- Unless otherwise noted on assembly drawings, all torque values must meet this specification.

Wrench & Fastener Size Guide



$1/4''$ Bolt or Nut
Wrench— $7/16''$

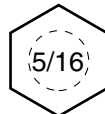

$5/16''$ Bolt or Nut
Wrench— $1/2''$

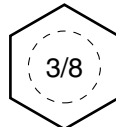

$3/8''$ Bolt or Nut
Wrench— $9/16''$

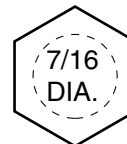

$7/16''$ Bolt or Nut
Wrench (Bolt)— $5/8''$
Wrench (Nut)— $11/16''$

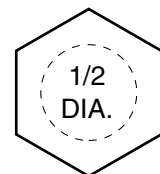

$1/2''$ Bolt or Nut
Wrench— $3/4''$

Parts Manual HydroCut Series Walk-Behind Mower

IT IS THE POLICY OF FERRIS INDUSTRIES TO IMPROVE ITS PRODUCTS WHENEVER IT IS POSSIBLE AND PRACTICAL TO DO SO. WE RESERVE THE RIGHT TO MAKE CHANGES OR ADD IMPROVEMENTS AT ANY TIME WITHOUT INCURRING ANY OBLIGATION TO MAKE SUCH CHANGES ON PRODUCTS MANUFACTURED PREVIOUSLY.



Ferris Industries

5375 North Main Street
Munnsville, NY 13409 USA
800-933-6175

www.ferrisindustries.com

© Copyright 2005 Ferris Industries
All Rights Reserved. Printed In USA.